



Circuit Protection T1

- T1.2 **Line protection using MCB's**
- T1.2 Protection against overloads
- T1.2 Protection of phase conductor
- T1.2 Protection of neutral conductor
- T1.3 Protection against short-circuit
- T1.6 Transformers in parallel
- T1.6 Let-through energy
- T1.7 Maximum protected cable length in the event of short-circuit (I_{cc} minimum)
- T1.8 **Definitions**
- T1.9 Characteristics according to **BS EN 60898**
- T1.11 Characteristics according to **BS EN 60947-2**
- T1.12 **Product related information**
- T1.14 **Selectivity**
- T1.19 **Association (Back-up protection)**
- T1.21 **Use in DC**
- T1.23 **Influence of ambient air temperature on the rated current**
- T1.24 **Effects of frequency on the tripping characteristic**
- T1.24 **Power losses**
- T1.24 **Limitation curves let-through energy I²t**
- T1.24 **Limitation curves peak current I_p**
- T1.31 **Tripping curves according to BS EN 60898**
- T1.32 **Text for specifiers**

People Protection T2

Add-on Devices T3

Comfort Functions T4



Line protection by means of MCB's

Protective devices shall be capable of breaking any overcurrent up to and including the prospective short-circuit current at the point where the device is installed. One of the protective devices complying with those conditions is the MCB.

Protection against overloads

According to IEC 60364-4-43 protective devices shall be provided to break any overload current flowing in the circuit conductors before such a current could cause a temperature rise detrimental to insulation, joints or surrounding goods to the conductors.

The operating characteristics of a device protecting a cable against overload shall satisfy the two following conditions:

$$I_B \leq I_n \leq I_Z$$

$$I_2 \leq 1.45 I_Z$$

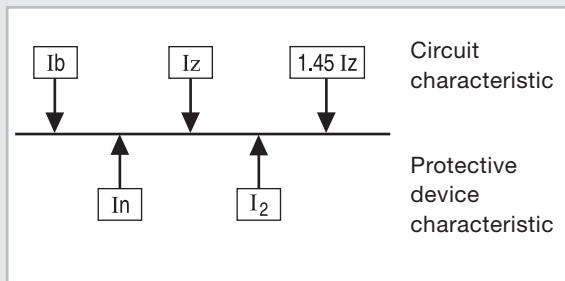

I_B = Current for which the circuit is designed.
 I_Z = Continuous current carrying capacity of the cable.
 I_n = Nominal current of the protective device.
 I_2 = Current ensuring effective operation of the protective device.

I_n and I_2 are values provided by the manufacturer of the protective device. Calculation of the cable cross section shall be done following the national wiring regulations as well as the IEC 60364-5-523 standard.

The maximum current admissible by the conductor (I_Z) depends of following factors:

1. Conductor cross-section.
2. Insulation material.
3. Composition of the conductor.
4. Ambient temperature.
5. Emplacement and canalisation.

Protection of phase conductor

Protection of overcurrent shall be provided for all phase conductors; it shall cause the disconnection of the conductor in which the overcurrent is detected, but not necessarily of other live conductor except in the following cases:

In TT or TN systems, for circuits supplied between phases and in which the neutral conductor is not distributed, overcurrent detection need to be provided for one of the phase conductors, provided that the following conditions are simultaneously fulfilled:

- There is, in the same circuit or on the supply side a differential protection intended to cause disconnection of all the phase conductors;
- The neutral conductor is not distributed from an artificial neutral point of the circuit situated on the load side of the differential protective device.

In IT systems it is mandatory to protect all the phase conductors.

Protection of neutral conductor

IT system

In IT systems it is strongly recommended that the neutral conductor should not be distributed. However, when the neutral conductor is distributed, it is generally necessary

Protection of phase conductor

Protection of overcurrent shall be provided for all phase conductors; it shall cause the disconnection of the conductor in which the overcurrent is detected, but not necessarily of other live conductor except in the following cases:

In TT or TN systems, for circuits supplied between phases and in which the neutral conductor is not distributed, overcurrent detection need to be provided for one of the phase conductors, provided that the following conditions are simultaneously fulfilled:

- There is, in the same circuit or on the supply side a differential protection intended to cause disconnection of all the phase conductors;
- The neutral conductor is not distributed from an artificial neutral point of the circuit situated on the load side of the differential protective device.

In IT systems it is mandatory to protect all the phase conductors.

TT & TN systems

Where the cross sectional area of the neutral conductor is at least equal or equivalent to that of the phase conductors, it is not necessary to provide overcurrent detection for the neutral conductor or a disconnecting device for that conductor. Where the cross sectional area of the neutral conductor is less than that of the phase conductor, it is necessary to provide overcurrent detection for the neutral conductor, appropriate to the cross-sectional area of that conductor; this connection shall cause the disconnection of the phase conductor, but not necessarily of the neutral conductor.

However, overcurrent detection does not need to be provided for the neutral conductor if the following two conditions are simultaneously fulfilled:

- The neutral conductor is protected against short-circuit by the protective device for the phase conductors of the circuit, and
- The maximum current likely to traverse the neutral conductor is, in normal service, clearly less than the value of the current-carrying capacity of that conductor.

	$S_N = S_F$	$S_N < S_F$			
System	III+N	III+N	III	I+N	II
TN-C , PEN conductor	3P	3P	-	P	-
TN-S separate PE & N conductors	3PN	3PN	3P	PN	2P
TT	3PN+ RCD	3PN+ RCD	3P+ RCD	PN+ RCD	2P+ RCD
IT	4P 3PN+ RCD	4P	3P	2P	2P

- S_N = Cross-section of neutral conductor
- S_F = Cross-section of phase conductor
- P = Protected pole
- RCD = Residual current device
- N = Neutral pole

Protection against short-circuit

According to IEC 60364 protective devices shall be provided to break any short-circuit current flowing in the circuit conductors before such a current could cause danger due to thermal and mechanical effects produced in conductors and connections. To consider that an installation is well protected against short-circuits, it is required that the protective device complies with the following conditions:

- The breaking capacity shall not be less than the prospective short-circuit current at the place of its installation.

$$I_{cu} \geq I_{cc}$$

- Let-through energy I^2t smaller than admissible energy of the cable.
- According to IEC 60364-4-473 there are some cases where the omission of devices for protection against overload is recommended for circuits supplying current-used equipment where unexpected opening of the circuit could cause danger. Examples of such a cases are:
 - Excitation circuit of rotating machines.
 - Supply circuit of lifting magnets.
 - Secondary circuits of current transformers.

As in those cases the $I_u > I_z$, it is necessary to verify the short-circuit value at the point of the installation to ensure the protection ($I_{cc \min}$)

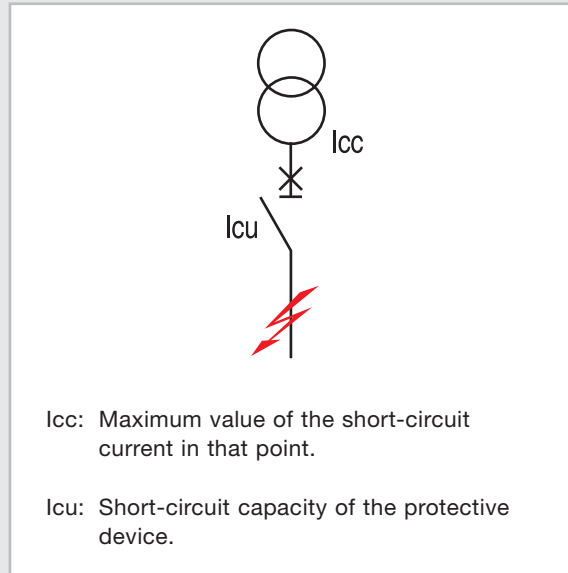

Calculation of I_{cc}

The value of the short-circuit current flowing at the end of a cable depends on the short-circuit current flowing at the beginning of the cable (transformer terminals), the cross section as well as its length.

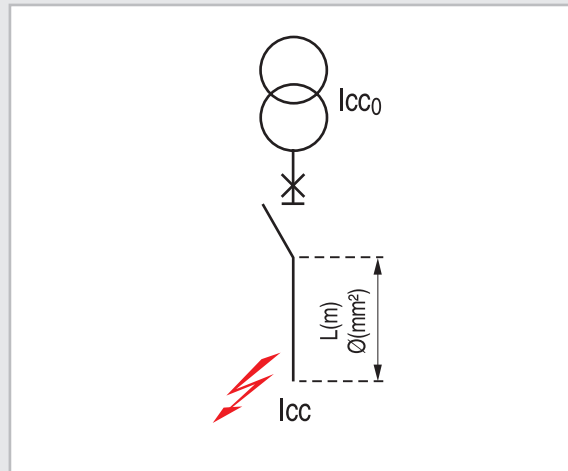

Short-circuit current at the transformer terminals (I_{cc0}) Three phase oil transformer - 400V

Transformer power kVA	Voltage U_{cc} in %	I_n A rms	I_{cc0} kA rms
250	4	352	8.7
315	4	443	10.9
400	4	563	13.8
500	4	704	17.1
630	4	887	21.6
800	4.5	1126	24.1
1000	5	1408	27
1250	5.5	1760	30.4
1600	6	2253	35.5
2000	6.5	2816	40.5
2500	7	3520	46.6
3150	7	4435	57.6



Calculation of the short-circuit current in function of:
 I_{CC0} , cross-section and length of the conductor.
 The following table provides information to calculate
 approximately the short-circuit current at a relevant
 point of the installation

mm ²	Length of the line in m																			
	0.8	1.0	1.2	1.3	1.5	1.6	1.7	2.0	2.1	2.2	2.5	2.6	3.0	3.1	3.5	3.6	4.0	4.1	4.5	4.6
1.5																				
2.5																				
4																				
6																				
10																				
16																				
25																				
35																				
50																				
70																				
95																				
120																				
150																				
185																				
240																				
300																				
400																				
500																				
625																				
2x95																				
2x120																				
2x150																				
2x185																				
2x240																				
3x95																				
3x120																				
3x150																				
3x185																				
3x240																				

I _{CC0} (kA)	Short-circuit current at the end of the cable																			
	0.8	1.0	1.2	1.3	1.5	1.6	1.7	2.0	2.1	2.2	2.5	2.6	3.0	3.1	3.5	3.6	4.0	4.1	4.5	4.6
100	94	93	92	91	90	83	70	66	62	55	49	33	20	16	14	11	8.8	4.7	2.4	1.9
90	85	84	84	83	82	76	65	62	58	52	47	32	19	16	14	11	8.7	4.7	2.4	1.9
80	76	76	75	74	74	69	60	57	54	48	44	31	19	16	14	11	8.6	4.7	2.4	1.9
70	67	67	66	66	65	61	54	52	49	44	41	29	18	15	13	10	8.5	4.6	2.4	1.9
60	58	57	57	57	56	54	48	46	44	40	37	27	18	15	13	10	8.3	4.6	2.4	1.9
50	49	48	48	48	47	45	41	40	38	35	33	25	17	14	12	9.8	8.1	4.5	2.4	1.9
40	39	39	39	39	38	37	34	33	32	30	28	22	15	13	12	9.3	7.8	4.4	2.3	1.9
35	34	34	34	34	34	33	30	30	29	27	26	21	15	13	11	9.0	7.6	4.4	2.3	1.9
30	29	29	29	29	29	28	27	26	25	24	23	19	14	12	11	8.6	7.3	4.3	2.3	1.8
25	25	25	24	24	24	24	23	22	22	21	20	17	12	11	9.9	8.2	7.0	4.2	2.3	1.8
20	20	20	20	20	20	19	18	18	18	17	17	14	11	10	9.0	7.5	6.5	4.0	2.2	1.8
15	15	15	15	15	15	15	14	14	14	13	13	12	9.4	9	7.8	6.7	5.9	3.7	2.1	1.7
10	9.9	9.9	9.9	9.9	9.9	9.8	9.6	9.5	9.4	9.2	9.1	8.3	7.1	7	6.2	5.5	4.9	3.3	2.0	1.6
7	7.0	7.0	7.0	7.0	6.9	6.9	6.8	6.8	6.7	6.6	6.5	6.1	5.5	5	4.9	4.4	4.1	2.9	1.8	1.5
5	5.0	5.0	5.0	5.0	5.0	5.0	4.9	4.9	4.9	4.8	4.8	4.5	4.2	4	3.8	3.5	3.3	2.5	1.7	1.4
4	4.0	4.0	4.0	4.0	4.0	4.0	3.9	3.9	3.9	3.9	3.8	3.7	3.4	3	3.2	3.0	2.8	2.2	1.5	1.3
3	3.0	3.0	3.0	3.0	3.0	3.0	3.0	3.0	2.9	2.9	2.9	2.8	2.7	3	2.5	2.4	2.3	1.9	1.4	1.2
2	2.0	2.0	2.0	2.0	2.0	2.0	2.0	2.0	2.0	2.0	2.0	1.9	1.9	2	1.8	1.7	1.7	1.4	1.1	1.0
1	1.0	1.0	1.0	1.0	1.0	1.0	1.0	1.0	1.0	1.0	1.0	1.0	1.0	1	0.9	0.9	0.9	0.8	0.7	0.7

- Values shorter than 0.8m or longer than 1 km are not considered.
- All values are for voltage 400V.

Example

Cable with cross section 95 mm² Cu ,
 45 m length, and short-circuit current at
 the transformer terminals of 30 kA.
 Estimated short-circuit current of **12 kA**
 at the end of the cable.

Correction coefficient

Voltage	K
230V	0.58
660V	1.65

Line protection - Aluminium conductor

mm ²	Length of the line																																			
1.5																1.0	1.9	3.8	4.8	5.8	7.9	9.9	19													
2.5																0.8	1.0	1.3	1.6	3.2	6.4	8.1	9.7	13	16	32										
4																1.0	1.3	1.6	2.1	2.6	5.1	10	13	16	21	26	51									
6																1.5	1.9	2.3	3.1	3.9	7.6	15	19	23	31	39	76									
10																1.3	2.5	3.2	3.9	5.2	6.6	13	25	32	39	52	66	127								
16																0.8	1.1	2.0	4.1	5.2	6.2	8.4	11	20	41	52	62	84	105	204						
25																0.8	1.0	1.3	1.6	3.2	6.4	8.1	9.7	13	16	32	64	81	97	131	164	319				
35																0.9	1.1	1.4	1.8	2.3	4.5	8.9	11.3	14	18	23	45	89	113	136	183	230	446			
50																1.3	1.6	1.9	2.6	3.3	6.4	13	16.1	19	26	33	64	127	161	195	262	329	637			
70																0.9	1.9	2.3	2.7	3.7	4.6	8.9	18	22.5	27	37	46	89	178	225	272	366	460	892		
95																1.2	2.5	3.1	3.7	5.0	6.2	12	24	30.6	37	50	62	121	242	306	370	497	625			
120																0.8	1.5	3.2	3.9	4.7	6.3	7.9	15	31	39	47	63	79	153	306	387	467	628	789		
150																0.9	1.7	3.5	4.2	5.1	6.8	8.6	17	33	42	51	68	86	166	333	420	508	683	858		
185																0.8	0.9	1.0	2.0	4.1	5.0	6.0	8.1	10	20	39	50	60	81	101	197	393	497	600	807	
240																0.9	1.0	1.2	1.3	2.4	5.2	6.2	7.5	10	13	24	49	62	75	100	126	245	490	618	747	
300																0.9	1.1	1.2	1.4	1.5	2.9	6.2	7.4	9.0	12	15	29	59	74	90	121	152	294	588	743	898
400																1.2	1.4	1.6	1.8	2.0	3.8	8.0	9.5	12	16	19	38	76	95	115	155	195	378	756	954	
500																1.4	1.7	1.9	2.2	2.4	4.6	9.6	12	14	19	23	46	91	115	139	187	235	455	911		
625																1.7	2.0	2.3	2.6	2.9	5.5	12	14	17	23	28	55	110	139	168	226	283	550			
2x95																0.9	1.0	1.1	1.3	2.4	5.1	6.1	7.4	9.9	12	24	48	61	74	99	125	242	484	612	739	994
2x120																0.9	1.1	1.3	1.4	1.6	3.1	6.4	7.7	9.3	13	16	31	61	77	93	126	158	306	612	773	934
2x150																1.0	1.2	1.4	1.6	1.8	3.3	7.0	8.4	10	14	17	33	67	84	102	137	172	333	665	840	
2x185																1.2	1.4	1.7	1.9	2.1	3.9	8.3	9.9	12	16	20	39	79	99	120	161	203	393	786	993	
2x240																1.5	1.8	2.1	2.3	2.6	4.9	10	12	15	20	25	49	98	124	149	201	253	490	979		
3x95																1.1	1.3	1.5	1.7	1.9	3.6	7.6	9.2	11	15	19	36	73	92	111	149	187	363	727	918	
3x120																1.4	1.7	1.9	2.2	2.4	4.6	9.7	12	14	19	24	46	92	116	140	188	237	459	918		
3x150																1.5	1.8	2.1	2.4	2.6	5.0	11	13	15	20	26	50	100	126	152	205	257	499	998		
3x185																1.8	2.2	2.5	2.8	3.1	5.9	12	15	18	24	30	59	118	149	180	242	304	590			
3x240																2.2	2.7	3.1	3.5	3.9	7.3	15	19	22	30	38	73	147	186	224	301	379	734			

icc _o (kA)	Short-circuit current at the end of the cable																							
100	94	93	92	91	90	83	70	66	62	55	49	33	20	16	14	11	8.8	4.7	2.4	1.9	1.6	1.2	1.0	0.5
90	85	84	84	83	82	76	65	62	58	52	47	32	19	16	14	11	8.7	4.7	2.4	1.9	1.6	1.2	1.0	0.5
80	76	76	75	74	74	69	60	57	54	48	44	31	19	16	14	11	8.6	4.7	2.4	1.9	1.6	1.2	1.0	0.5
70	67	67	66	66	65	61	54	52	49	44	41	29	18	15	13	10	8.5	4.6	2.4	1.9	1.6	1.2	1.0	0.5
60	58	57	57	57	56	54	48	46	44	40	37	27	18	15	13	10	8.3	4.6	2.4	1.9	1.6	1.2	0.9	0.5
50	49	48	48	48	47	45	41	40	38	35	33	25	17	14	12	9.8	8.1	4.5	2.4	1.9	1.6	1.2	0.9	0.5
40	39	39	39	39	38	37	34	33	32	30	28	22	15	13	12	9.3	7.8	4.4	2.3	1.9	1.6	1.2	0.9	0.5
35	34	34	34	34	34	33	30	30	29	27	26	21	15	13	11	9.0	7.6	4.4	2.3	1.9	1.6	1.2	0.9	0.5
30	29	29	29	29	29	28	27	26	25	24	23	19	14	12	11	8.6	7.3	4.3	2.3	1.8	1.5	1.2	0.9	0.5
25	25	25	24	24	24	24	23	22	22	21	20	17	12	11	9.9	8.2	7.0	4.2	2.3	1.8	1.5	1.2	0.9	0.5
20	20	20	20	20	20	19	18	18	17	17	14	11	10	9.0	7.5	6.5	4.0	2.2	1.8	1.5	1.1	0.9	0.5	
15	15	15	15	15	15	15	14	14	14	13	13	12	9.4	9	7.8	6.7	5.9	3.7	2.1	1.7	1.5	1.1	0.9	0.5
10	9.9	9.9	9.9	9.9	9.9	9.8	9.6	9.5	9.4	9.2	9.1	8.3	7.1	7	6.2	5.5	4.9	3.3	2.0	1.6	1.4	1.1	0.9	0.5
7	7.0	7.0	7.0	7.0	6.9	6.9	6.8	6.8	6.7	6.6	6.5	6.1	5.5	5	4.9	4.4	4.1	2.9	1.8	1.5	1.3	1.0	0.8	0.5
5	5.0	5.0	5.0	5.0	5.0	5.0	4.9	4.9	4.9	4.8	4.8	4.5	4.2	4	3.8	3.5	3.3	2.5	1.7	1.4	1.2	1.0	0.8	0.5
4	4.0	4.0	4.0	4.0	4.0	4.0	3.9	3.9	3.9	3.9	3.8	3.7	3.4	3	3.2	3.0	2.8	2.2	1.5	1.3	1.2	0.9	0.8	0.4
3	3.0	3.0	3.0	3.0	3.0	3.0	3.0	3.0	2.9	2.9	2.9	2.8	2.7	3	2.5	2.4	2.3	1.9	1.4	1.2	1.1	0.9	0.7	0.4
2	2.0	2.0	2.0	2.0	2.0	2.0	2.0	2.0	2.0	2.0	2.0	1.9	1.9	2	1.8	1.7	1.7	1.4	1.1	1.0	0.9	0.8	0.7	0.4
1	1.0	1.0	1.0	1.0	1.0	1.0	1.0	1.0	1.0	1.0	1.0	1.0	1.0	1	0.9	0.9	0.9	0.8	0.7	0.7	0.6	0.5	0.5	0.3

- Values shorter than 0.8m or longer than 1 km are not considered.
- All values are for voltage 400V.

Example
 Cable with cross section 150 mm² Al, 65 m length, and short-circuit current at the transformer terminals of 10 kA.
 Estimated short-circuit current of **5.5 kA** at the end of the cable.

Correction coefficient

Voltage	K
230V	0.58
660V	1.65



Transformers in parallel

In the case of several transformers in parallel there are some points of the installation where the I_{cc} is the sum of the short-circuit currents provided by each transformer .

The short-circuit capacity of the protective devices shall be calculated taking into consideration the following criteria:

- Short-circuit in A: $I_{cu1} \geq I_{cc2} + I_{cc3}$
- Short-circuit in F: $I_{cu2} \geq I_{cc2}$
- Short-circuit in D: $I_{cu4} \geq I_{cc1} + I_{cc2} + I_{cc3}$

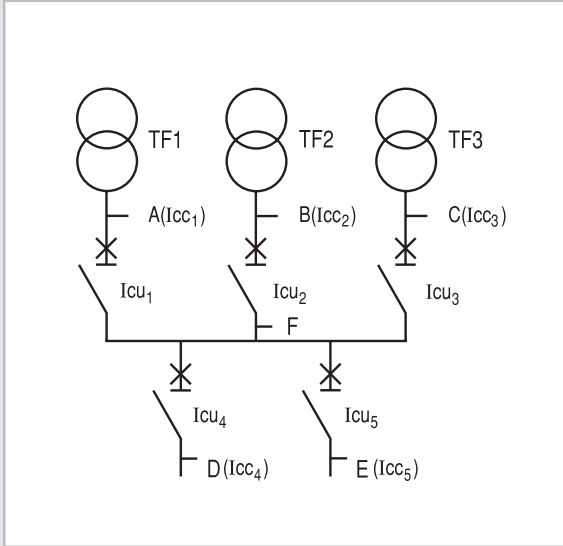

Let-through energy

The standard IEC 60364 describes that the current limiting of the conductors (K^2S^2) shall be equal or greater than the let-through energy (I^2t) quoted by the protective device. The K coefficient depends on the conductor insulation.

S is the cross section of the conductor.

$$I^2t \leq K^2S^2$$

Copper conductor

Insulation	PVC	Rubber	Polyethylene XLPE
K=	115	135	146
Cross section mm ²	Maximum admissible value $K^2S^2 \times 10^3$		
1.5	30	41	48
2.5	83	114	133
4	212	292	341
6	476	656	767
10	1323	1823	2132
16	3386	4666	5457
25	8266	11391	13323
35	16201	22326	26112
50	33063	45563	53290
70	64803	89303	104448
95	119356	164481	192377
120	190440	262440	306950
150	297563	410063	479610
185	452626	623751	729540
240	761760	1049760	1227802

Aluminium conductor

Insulation	PVC	Rubber	Polyethylene XLPE
K=	74	87	94
Cross section mm ²	Maximum admissible value $K^2S^2 \times 10^3$		
10	548	757	884
16	1402	1938	2262
25	3423	4731	5523
35	6708	9272	10824
50	13690	18923	22090
70	26832	37088	43296
95	49421	68310	79745
120	78854	108994	127238
150	123210	170303	198810
185	187416	259049	302412
240	315418	435974	508954

Maximum protected cable length in the event of short-circuit (I_{cc} minimum)

The following values are applicable in case that the protective device does not exist or is over-rated. They are calculated according to the formula:

$$I_{cc} = \frac{0.8 \cdot U \cdot S}{1.5 \cdot \rho \cdot 2 \cdot L} \cdot K$$

- U: Voltage 400V
- 0.8: Reduction coefficient due to impedances
- S: Conductor cross section
- ρ: Cu resistivity: 0.025 Ω mm²/m
- L: Conductor length
- K: Correction coefficient

It is possible to determine the maximum cable length protected in the event of short-circuit current in function of:

- The nominal current,
- The nominal voltage,
- The conductor characteristic
- The magnetic tripping characteristic of the protective device.

The short-circuit current at any point of the installation shall be high enough to disconnect the protective device.

To ensure the MCB disconnection, we needed to take into consideration the following table

Maximum protected cable length in case of short-circuit

For network 3x400 V without N, Tripping characteristic C (I_m: 10 x I_n)

In (A)	0.5	1	2	4	6	10	16	20	25	32	40	50	63	80	100	125	160	250	400	630	800	1000	1250	1600	2000				
S mm ²	Maximum protected length (m) for Cu conductor																												
1.5	1778	889	444	222	148	89	56	44	36	28	22																		
2.5		1481	741	370	237	148	93	74	59	46	37	30	24																
4			1185	593	356	237	148	119	95	74	59	47	38	30															
6				1778	889	593	356	222	178	142	111	89	71	56	44	36													
10					1481	948	593	370	296	237	185	148	119	94	74	59	47												
16						1481	948	593	474	379	296	237	190	150	119	95	76	59											
25							1481	926	741	593	463	370	296	235	185	148	119	93											
35								1296	1037	830	648	519	415	329	259	207	166	130	83										
50									1852	1481	1185	926	741	593	470	370	296	237	185	119									
70										1659	1296	1037	830	658	519	415	332	259	166	104									
95											1759	1407	1126	894	704	563	450	352	225	141									
120												1778	1422	1129	889	711	569	444	284	178	113								
150													1932	1546	1227	966	773	618	483	309	193	123							
185														1827	1450	1142	914	731	571	365	228	145	114						
240															1806	1422	1138	910	711	455	284	181	142	114					
300																1709	1368	1094	855	547	342	217	171	137					
400																	1852	1481	1185	926	593	370	235	185	148	119			
500																		1646	1317	1029	658	412	261	206	165	132			
625																			1684	1347	1052	673	421	267	210	168	135	105	
2x95													1787	1407	1126	901	704	450	281	179	141	113							
2x120														1778	1422	1138	889	569	356	226	178	142	114						
2x150															1932	1546	1237	966	618	386	245	193	155	124					
2x185																1827	1437	1142	731	457	290	228	183	146	114				
2x240																	1462	1422	910	569	361	284	228	182	142	114			
3x95																		1689	1820	1056	676	422	268	211	169	135	106		
3x120																			1351	1333	853	533	339	267	213	171	133	107	
3x150																				1707	1449	928	580	368	290	232	186	145	116
3x185																				1855	1713	096	685	435	243	274	219	171	137
3x240																					365	853	542	427	341	273	213	171	

Example

Network 3x400+N with a copper conductor of 95mm² cross-section and using as a protection device a MCB C63.

Maximum cable length:
L_{max} = 894 x 0.58 x 0.5 = 259m

Correction coefficients

Tripping characteristic	Voltage		Conductor		Cross section > 120 mm ²		Number of cables in parallel	
	K1	K2	K3	K4	K4	K5		
Curve B	x 2	2 x 230 V	Aluminium	x 0.90	120	1		
Curve D	x 0.5	x 0.58		x 0.85	150	2		
Curve K	x 1.6	3 x 400V + N		x 0.80	185	3		
Curve Gi	x 0.8	230V Phase-N		x 0.75	240	4		
Curve Im	x 10/lm	3 x 400V + N/2		x 0.72	300	5		
		x 0.39						



Definitions related to MCB's

MCB= Miniature Circuit Breakers

Short-circuit (making and breaking) capacity

Alternating component of the prospective current, expressed by its r.m.s. value, which the circuit-breaker is designed to make, to carry for its opening time and to break under specified conditions.

Ultimate or rated short-circuit breaking capacity (I_{cn} - EN 60898)

A breaking capacity for which the prescribed conditions, according to a specified test sequence do not include the capability of the MCB to carry 0.96 times its rated current for the conventional time.

Ultimate short-circuit breaking capacity (I_{cu} - EN 60947-2)

A breaking capacity for which the prescribed conditions, according to a specified test sequence do not include the capability of the MCB to carry its rated current for the conventional time.

Service short-circuit breaking capacity (I_{cs} - EN 60898)

A breaking capacity for which the prescribed conditions according to a specified test sequence include the capability of the MCB to carry 0.96 times its rated current for the conventional time.

Service short-circuit breaking capacity (I_{cs} - EN 60947-2)

A breaking capacity for which the prescribed conditions according to a specified test sequence include the capability of the MCB to carry its rated current for the conventional time.

Prospective current

The current that would flow in the circuit, if each main current path of the MCB were replaced by a conductor of negligible impedance.

Conventional non-tripping current (I_{nt})

A specified value of current which the circuit breaker is capable of carrying for a specified time without tripping.

Conventional tripping current (I_t)

A specified value of current which causes the circuit breaker to trip within a specified time.

Open position

The position in which the predetermined clearance between open contacts in the main circuit of the MCB is secured.

Closed position

The position in which the predetermined continuity of the main circuit of the MCB is secured.

Maximum prospective peak current (I_p)

The prospective peak current when the initiation of the current takes place at the instant which leads to the highest possible value.

Characteristics according to BS EN 60898

Miniature Circuit Breakers are intended for the protection of wiring installations against both overloads and short-circuits in domestic or commercial wiring installations where operation is possible by uninstructed people.

Tripping characteristic curves

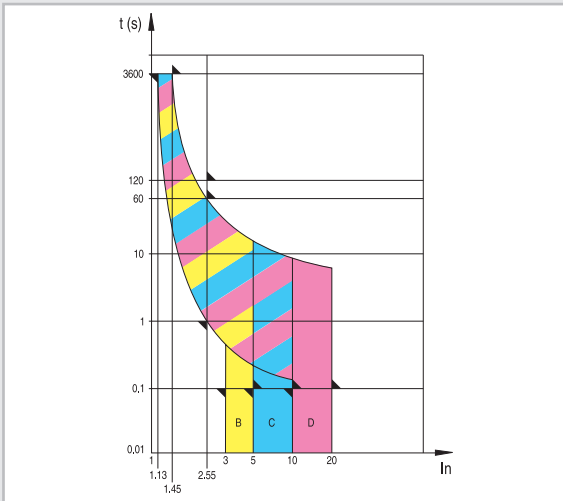

Magnetic release

An electromagnet with plunger ensures instantaneous tripping in the event of short-circuit. The standard distinguishes three different types, following the current for instantaneous release: type B,C,D.

lcn (A)	Test current	Tripping time	Applications
B	3 x In 5 x In	0.1 < t < 45s (In ≤ 32A) 0.1 < t < 90s (In > 32A) t < 0.1s	Only for resistive loads such as: - electrical heating - water heater - stoves
C	5 x In 10 x In	0.1 < t < 15s (In ≤ 32A) 0.1 < t < 30s (In > 32A) t < 0.1s	Usual loads such as: - lighting - socket outlets - small motors
D	10 x In 20 x In	0.1 < t < 4s(**) (In ≤ 32A) 0.1 < t < 8s (In > 32A) t < 0.1s	Control and protection of circuits having important transient inrush currents (large motors)

Thermal release

The release is initiated by a bimetal strip in the event of overload. The standard defines the range of releases for specific overload values. Reference ambient temperature is 30°C.

Test current	Tripping time
1.13 x In	t ≥ 1h (In ≤ 63A) t ≥ 2h (In > 63A)
1.45 x In	t < 1h (In ≤ 63A) t < 2h (In > 63A)
2.55 x In	1s < t < 60s (In ≤ 32A) 1s < t < 120s (In > 32A)

Rated short-circuit breaking capacity (Icn)

Is the value of the short-circuit that the MCB is capable of withstanding in the following test of sequence of operations: O-t-CO

After the test the MCB is capable, without maintenance to withstand a dielectric strength test at a test voltage of 900V. Moreover the MCB shall be capable of tripping when loaded with 2.8 In within the time corresponding to 2.55 In but greater than 0.1s.

Service short-circuit breaking capacity (Ics)

Is the value of the short-circuit that the MCB is capable of withstanding in the following test of sequence of operations: O-t-CO-t-CO

After the test the MCB is capable, without maintenance to withstand a dielectric strength test at a test voltage of 1.500V. Moreover the MCB shall not trip when a current of 0.96 In. The MCB shall trip within 1h when current is 1.6 In.

- O - Represents an opening operation
- CO - Represents a closing operation followed by an automatic opening.
- t - Represents the time interval between two successive short-circuit operations: 3 minutes.

The relation between the Rated short-circuit capacity (Icn) and the Rated service short-circuit breaking capacity (Ics) shall be as follows:

Icn (A)	Ics (A)
≤ 6000	6000
> 6000	0.75 Icn min. 6000
≤ 10000	
> 10000	0.75 Icn min. 7500

In both sequences all MCB's are tested for emission of ionized gases during short-circuit (grid distance), in a safety distance between two MCB's of 35 mm when devices are installed in two different rows in the enclosure. This performance allows the use of any GE Power Controls enclosure.

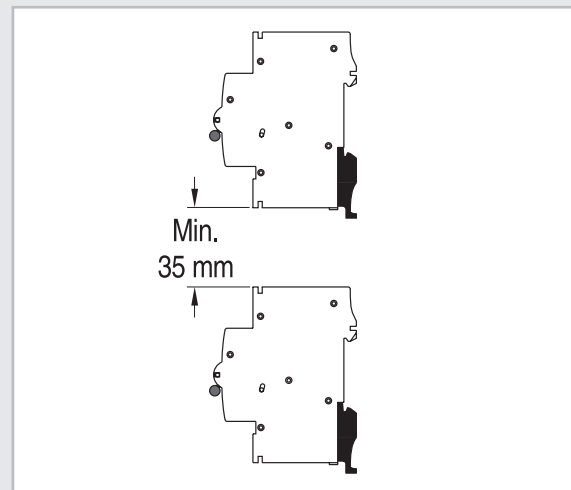

Information on product according to BS EN 60898

Example: 2P MCB B characteristic 32A

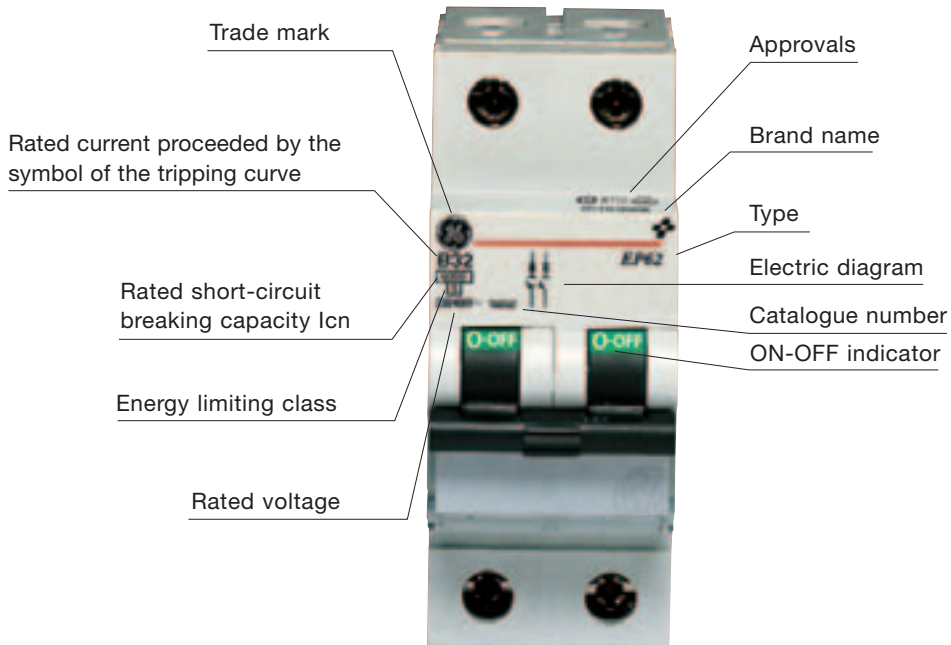

T1

Use of an MCB

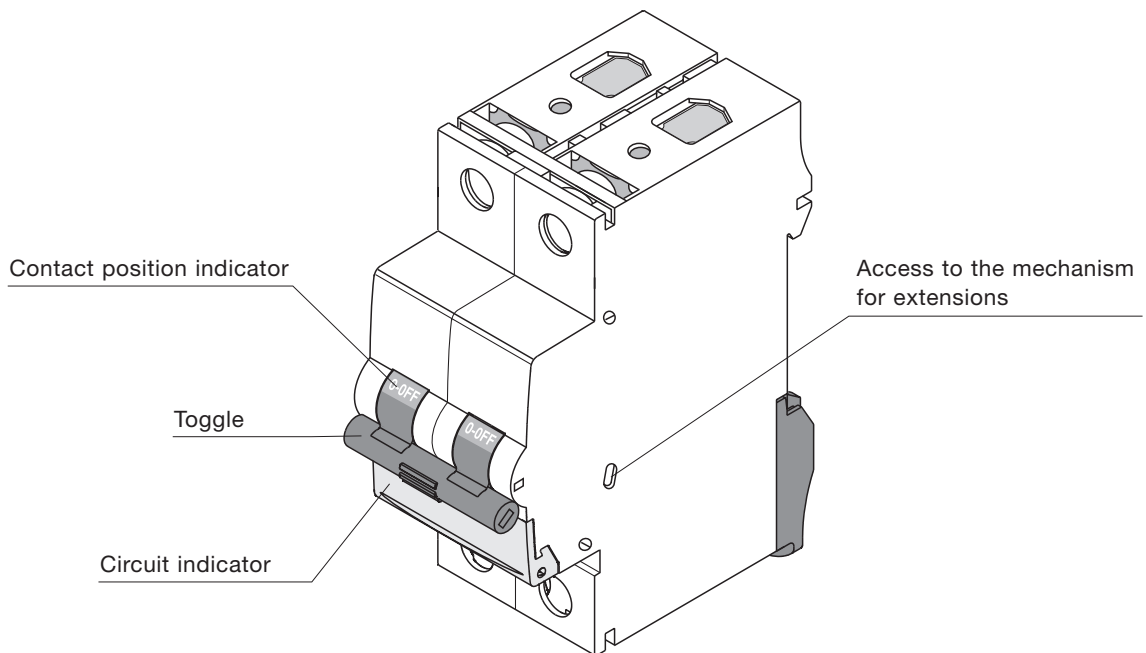

Characteristics according to EN 60947-2

Miniature Circuit Breakers are intended for the protection of the lines against both overloads and short-circuits in industrial wiring installations where normally operation is done by instructed people.

Tripping characteristic curves

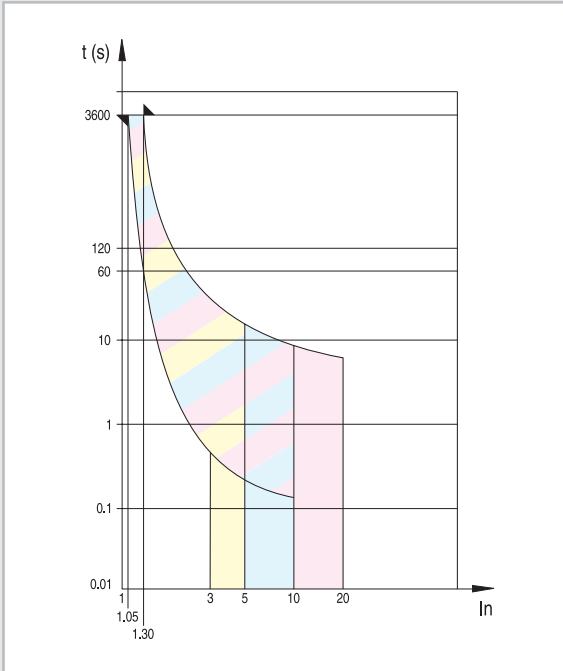

Magnetic release

An electromagnet with plunger ensures instantaneous tripping in the event of short-circuit. The standard leaves the calibration of magnetic release to the manufacturer's discretion.

GE Power Controls offers instantaneous tripping ranges:

- release between 3 and 5 In
- release between 5 and 10 In
- release between 10 and 20 In

Thermal release

The release is initiated by a bimetal strip in the event of overload. The standard defines the range of release for two special overload values. Reference ambient temperature is 40°C.

Test current	Tripping time
1.05 x In	t ≥ 1h (In ≤ 63A) t ≥ 2h (In > 63A)
1.30 x In	t < 1h (In ≤ 63A) t < 2h (In > 63A)

Rated ultimate short-circuit breaking capacity (Icu).

Is the value of the short-circuit that the MCB is capable of withstanding in the following test of sequence of operations: O-t-CO

After the test the MCB is capable, without maintenance, to withstand a dielectric strength test at a test voltage of 1000V. Moreover the MCB shall be capable of tripping when loaded with 2.5 In within the time corresponding to 2In but greater than 0.1s.

Rated service short-circuit breaking capacity (Ics).

Is the value of the short-circuit that the MCB is capable of withstanding in the following test of sequence of operations: O-t-CO-t-CO

After the test the MCB is capable, without maintenance, to withstand a dielectric strength test at a test voltage of twice its rated insulation voltage with a minimum of 1000V. A verification of the overload releases on In and moreover the MCB shall trip within 1h when current is 1.45 In (for In < 63A) and 2h (for In > 63A).

- O - Represents an opening operation
- CO - Represents a closing operation followed by an automatic opening.
- t - Represents the time interval between two successive short-circuit operations: 3 minutes.

Category A: Without a short-time withstand current rating.

Utilization category	Application with respect to selectivity
A	Circuit breakers not specifically intended for selectivity under short-circuit conditions with respect to other short-circuit protective devices in series on the load side, i.e. without an intentional short-time delay provided for selectivity under short-circuit conditions, and therefore without a short-time withstand current rating according to 4.3.5.4
B	Circuit breakers specifically intended for selectivity under short-circuit conditions with respect to other short-circuit protective devices in series on the load side, i.e. without an intentional short-time delay (which may be adjustable), provided for selectivity under short-circuit conditions. Such circuit-breakers have a short-time withstand current rating according to 4.3.5.4



Information on product according to EN 60947-2

Example: EP250 1P 20A 5 to 10 lu

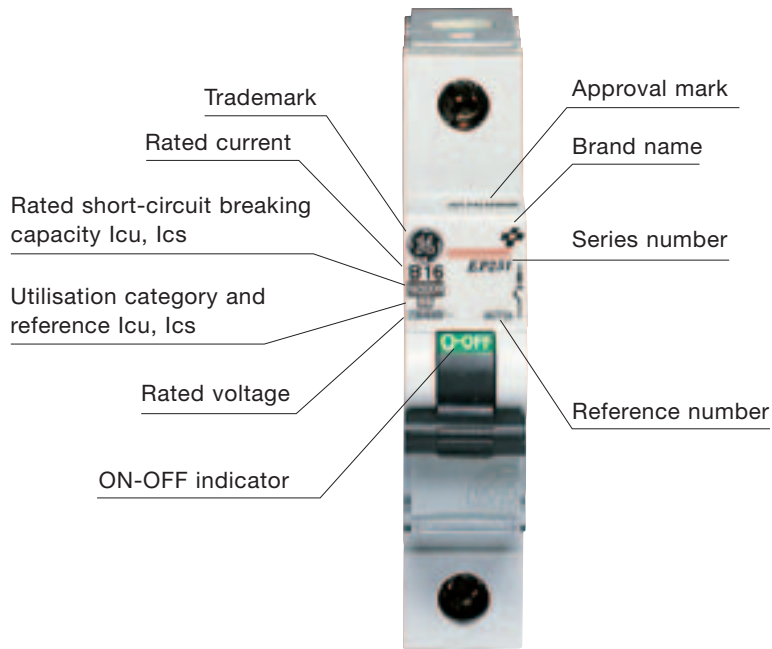

Use of an MCB

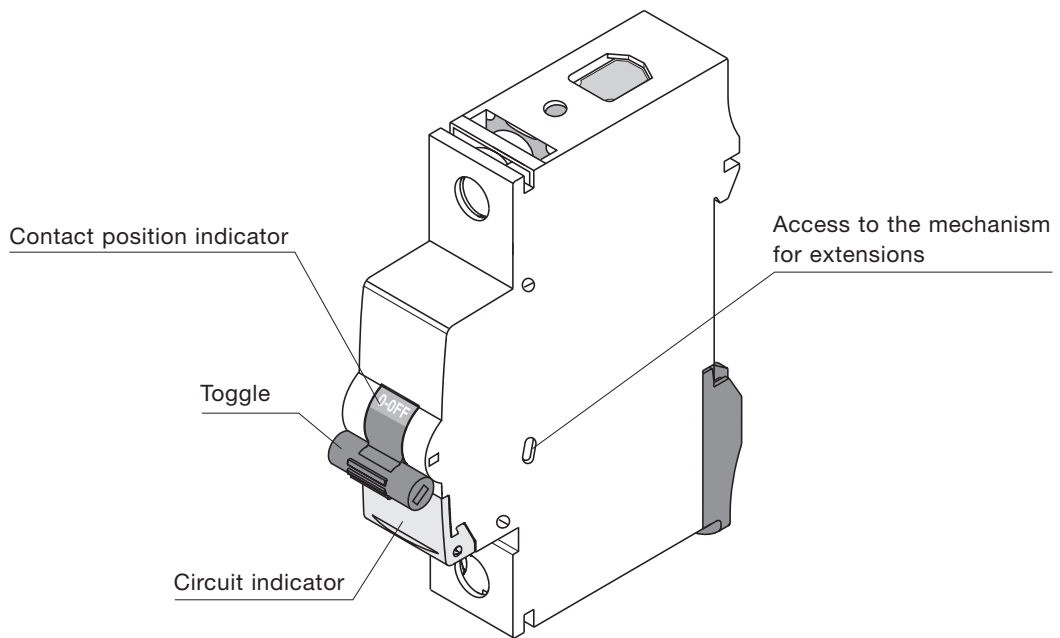

CIRCUIT INDICATOR

For end-user circuit identification. It is possible to identify the electrical circuits by placing a label with pictograms which is possible to make with an adapted software.

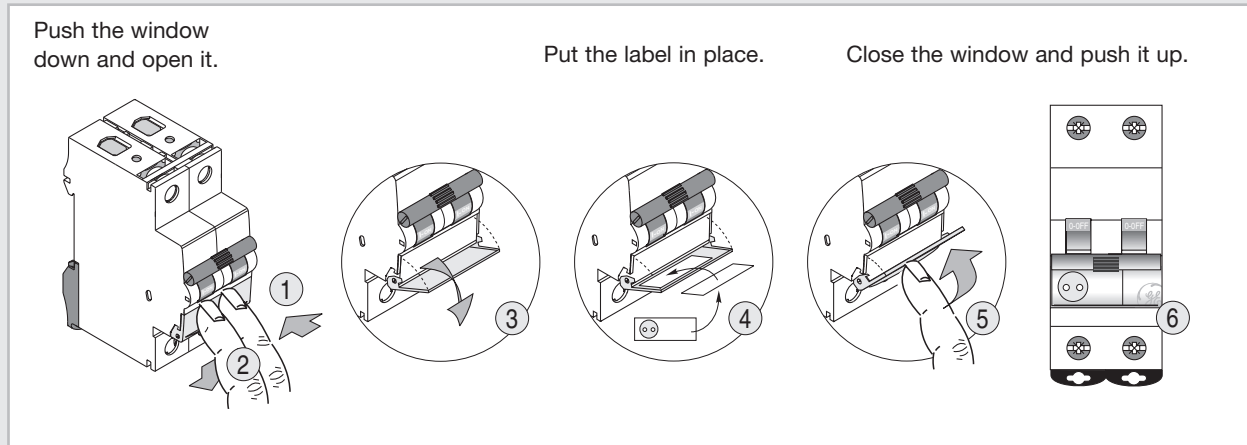

ACCESS TO THE MECHANISM FOR EXTENSIONS

Connection of the extensions.

It is possible to couple any auxiliary contact, shunt trip, undervoltage release or motor driver either on the right or the left hand side, following the stack-on configuration of the extensions in page T3.14

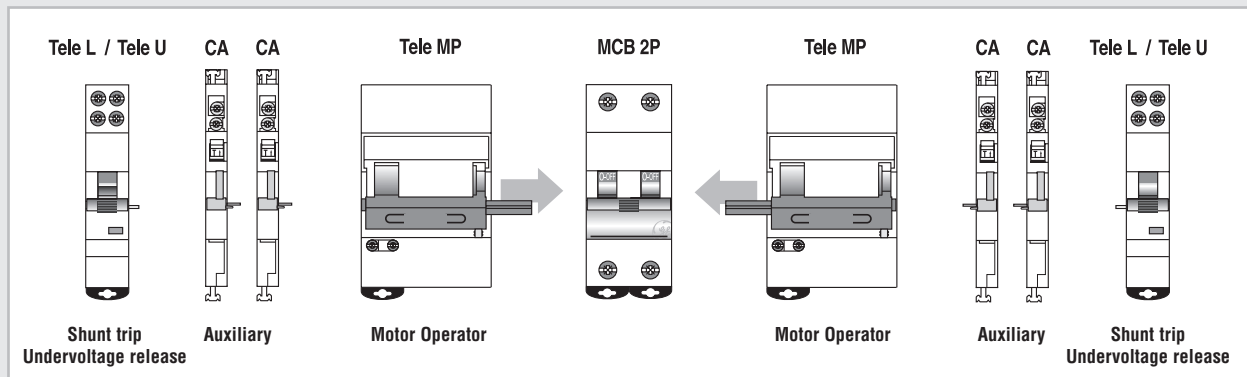

TOGGLE

To switch the MCB ON or OFF

CONTACT POSITION INDICATOR

Printing on the toggle to provide information of the real contact position.

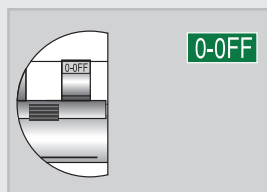

O-OFF
Contacts in open position. Ensure a distance between contacts > 4mm.

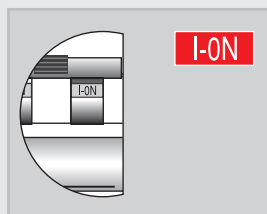

I-ON
Contacts in closed position. Ensure continuity in the main circuit.



Selectivity

An installation with some protective devices in series (a protective device must be placed at the point where a reduction of the cross sectional area of the conductors or another change causes modification in the characteristics of the installation) is considered as selective when, in the event of short-circuit, the installation is interrupted only by the device which is immediately upstream of the fault point. Selectivity is ensured when the characteristic time/current of the upstream MCB (A) is above the characteristic time/current of the downstream MCB (B). Selectivity may be total or partial.

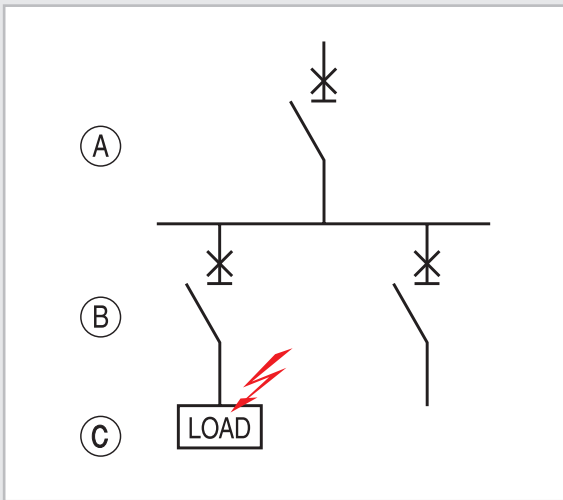

Total selectivity

Selectivity is total in the event of a short-circuit fault and only disconnects the protective device B immediately upstream of the fault point.

The let-through energy (I^2t) of the downstream protective device shall be lower than the one of the upstream protective device.

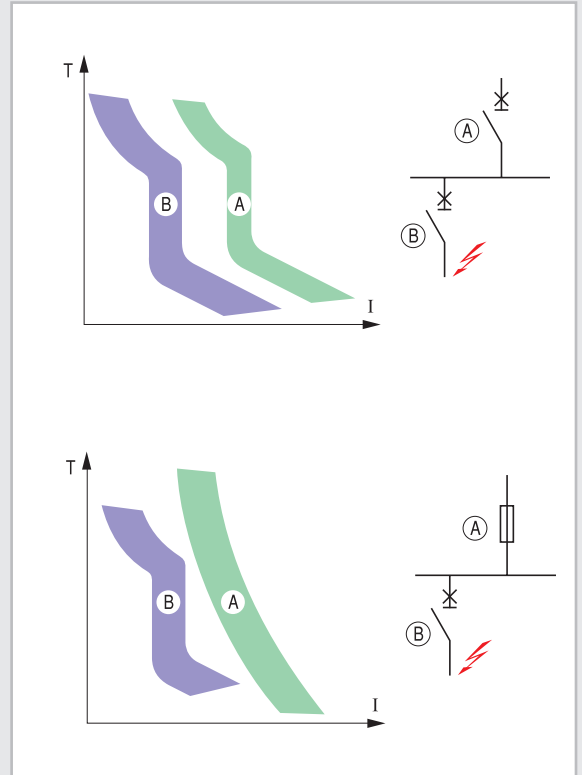

Partial selectivity

Selectivity is partial when the disconnection of the protective device (A) is ensured only up to a certain level of the current.

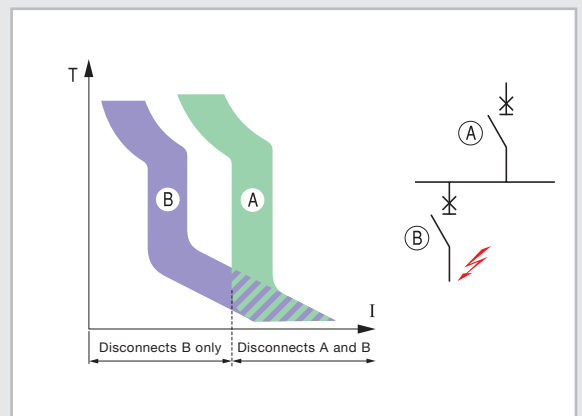

Selectivity - Upstream: MCB's / Downstream: MCB's

MCB's		Upstream C curve										
		EP60 - EP100 - EP250							Hti			
MCB's		10A	16A	20A	25A	32A	40A	50A	63A	80A	100A	125A
Downstream	In (A)											
B curve												
EP60	6	0.07	0.10	0.15	0.18	0.23	0.27	0.35	0.45	T	T	T
EP100	10	-	-	0.15	0.18	0.23	0.27	0.35	0.45	6	T	T
EP250	16	-	-	-	-	0.23	0.27	0.35	0.45	4	6	6
	20	-	-	-	-	0.23	0.27	0.35	0.45	4	6	6
	25	-	-	-	-	-	0.27	0.35	0.45	3.5	6	6
	32	-	-	-	-	-	0.27	0.35	0.45	3.5	6	6
	40	-	-	-	-	-	-	-	-	1.6	5	5
	50	-	-	-	-	-	-	-	-	-	-	-
	63	-	-	-	-	-	-	-	-	-	-	

MCB's		Upstream C curve										
		EP60 - EP100 - EP250							Hti			
MCB's		10A	16A	20A	25A	32A	40A	50A	63A	80A	100A	125A
Downstream	In (A)											
C curve												
EP60	6	0.07	0.10	0.15	0.18	0.23	0.27	0.35	0.45	4.5	6	6
EP100	10	-	-	0.15	0.18	0.23	0.27	0.35	0.45	4.5	6	6
EP250	16	-	-	-	-	-	0.27	0.35	0.45	2	5	5
	20	-	-	-	-	-	0.27	0.35	0.45	2	5	5
	25	-	-	-	-	-	0.27	0.35	0.45	1.5	4.5	4.5
	32	-	-	-	-	-	-	0.35	0.45	1.5	2.3	2.3
	40	-	-	-	-	-	-	-	0.45	-	2.3	2.3
	50	-	-	-	-	-	-	-	-	-	-	-
	63	-	-	-	-	-	-	-	-	-	-	

T = Full selectivity

Example

A combination of an MCB C20 with an upstream MCB C100 guarantees selectivity up to a short-circuit level of 5 kA.

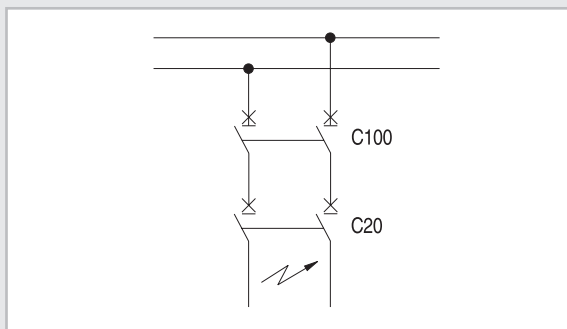

Selectivity - Upstream: Fuses / Downstream: MCB's EP60

Fuses MCB's	Upstream: Fuses BS 1361						
	(A)	40	63	80	100	125	160
Downstream MCB EP60 B curve (A)							
6	2.3	6.0	6.0	6.0	6.0	6.0	6.0
10	1.8	5.0	6.0	6.0	6.0	6.0	6.0
16	1.5	4.2	5.8	6.0	6.0	6.0	6.0
20	1.3	3.4	4.8	5.3	6.0	6.0	6.0
25		3.2	4.3	4.7	6.0	6.0	6.0
32		2.8	3.8	4.2	6.0	6.0	6.0
40		2.7	3.6	4.0	5.6	6.0	6.0
50				3.7	5.3	6.0	6.0
63				3.2	4.5	6.0	6.0

Fuses MCB's	Upstream: Fuses BS 1361						
	(A)	40	63	80	100	125	160
Downstream MCB EP60 C curve (A)							
6	2.0	5.3	6.0	6.0	6.0	6.0	10.0
10	1.6	4.2	5.5	6.0	6.0	6.0	6.0
16	1.4	3.8	5.0	5.7	6.0	6.0	6.0
20	1.2	3.4	4.2	4.8	6.0	6.0	6.0
25		3.0	3.9	4.4	6.0	6.0	6.0
32		2.8	3.4	3.9	5.8	6.0	6.0
40		2.5	3.1	3.5	5.3	6.0	6.0
50				3.2	4.7	6.0	6.0
63				2.9	4.2	6.0	6.0

Fuses MCB's	Upstream: Fuses BS 1361						
	(A)	40	63	80	100	125	160
Downstream MCB EP60 D curve (A)							
6	1.7	6.0	6.0	6.0	6.0	6.0	6.0
10	1.4	3.9	5.2	5.8	6.0	6.0	6.0
16	1.4	3.6	4.7	5.2	6.0	6.0	6.0
20	1.2	3.1	4.1	4.6	6.0	6.0	6.0
25	1.0	2.8	3.7	4.1	6.0	6.0	6.0
32		2.3	3.2	3.5	5.4	6.0	6.0
40		2.1	2.9	3.3	5.0	6.0	6.0
50				3.0	4.7	6.0	6.0
63				2.6	4.2	6.0	6.0

Example

A combination of an MCB C20 with an upstream fuse 80A guarantees selectivity up to a short-circuit level of 4.2 kA.

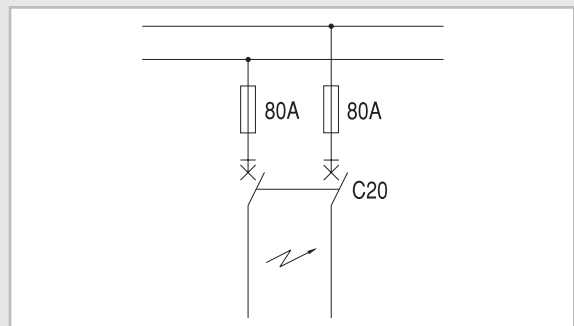

Selectivity - Upstream: Fuses / Downstream: MCB's EP100

Fuses		Upstream: Fuses BS 1361					
MCB's	(A)	40	63	80	100	125	160
Downstream MCB EP100 B curve (A)							
6		2.3	6.8	10.0	10.0	10.0	10.0
10		1.8	5.0	7.0	8.0	10.0	10.0
16		1.5	4.2	5.8	6.5	9.6	10.0
20		1.3	3.4	4.8	5.3	7.5	10.0
25			3.2	4.3	4.7	7.0	10.0
32			2.8	3.8	4.2	6.0	10.0
40			2.7	3.6	4.0	5.6	10.0
50					3.7	5.3	10.0
63					3.2	4.5	10.0

Fuses		Upstream: Fuses BS 1361					
MCB's	(A)	40	63	80	100	125	160
Downstream MCB EP100 C curve (A)							
6		2.0	5.3	7.2	8.5	10.0	10.0
10		1.6	4.2	5.5	6.5	10.0	10.0
16		1.4	3.8	5.0	5.7	8.6	10.0
20		1.2	3.4	4.2	4.8	7.3	10.0
25			3.0	3.9	4.4	6.7	10.0
32			2.8	3.4	3.9	5.8	10.0
40			2.5	3.1	3.5	5.3	10.0
50					3.2	4.7	10.0
63					2.9	4.2	9.4

Fuses		Upstream: Fuses BS 1361					
MCB's	(A)	40	63	80	100	125	160
Downstream MCB EP100 D curve (A)							
6		1.7	10.0	10.0	10.0	10.0	10.0
10		1.4	3.9	5.2	5.8	8.8	10.0
16		1.4	3.6	4.7	5.2	7.6	10.0
20		1.2	3.1	4.1	4.6	6.8	10.0
25		1.0	2.8	3.7	4.1	6.1	10.0
32			2.3	3.2	3.5	5.4	10.0
40			2.1	2.9	3.3	5.0	10.0
50					3.0	4.7	10.0
63					2.6	4.2	9.6

Example

A combination of an MCB C20 with an upstream fuse 80A guarantees selectivity up to a short-circuit level of 4.2 kA.

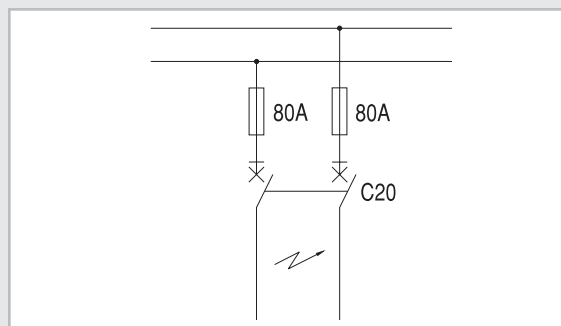

Selectivity - Upstream: MCCB's / Downstream: MCB's

MCCB's \ MCB's	Upstream: Moulded case circuit breakers																						
	FD125S				FD125N				D125-D125L				D160-DH160-D160L-D250-DH250-D250L										
	63A	80A	100A	125A	40A	50A	63A	80A	100A	125A	16A	25A	40A	63A	80A	100A	125A	63A	100A	125A	160A	200A	250A
Downstream: MCB's (A)																							
EP60 C curve	6	T	T	T	T	T	T	T	T	T	0.3	1.2	1.8	1.6	4.5	6	6	6	T	T	T	T	T
10	T	T	T	T	T	T	T	T	T	T	--	1.2	1.4	1.5	4.5	6	6	6	T	T	T	T	T
16	T	T	T	T	T	T	T	T	T	T	--	--	1	1.2	2	5	5	4.5	T	T	T	T	T
20	T	T	T	T	3.5	3	T	T	T	T	--	--	1	1.2	2	5	5	4.5	T	T	T	T	T
25	T	T	T	T	2.5	2.5	T	T	T	T	--	--	0.4	0.8	1.5	4.5	4.5	4.5	T	T	T	T	T
32	T	T	T	T	--	--	T	T	T	T	--	--	0.5	1.5	2.3	2.3	3	7.5	T	T	T	T	T
40	--	T	T	T	--	--	T	T	T	T	--	--	--	--	--	2.3	2.3	2	7.5	7.5	T	T	T
50	--	--	T	T	--	--	--	3.5	T	T	--	--	--	--	--	--	--	2	4.5	6	T	T	T
63	--	--	T	T	--	--	--	--	T	T	--	--	--	--	--	--	--	2	4.5	6	T	T	T
EP100 C curve	6	T	T	T	T	6	6	T	T	T	0.3	1.2	1.8	1.6	4.5	6	6	6	10	10	13	T	T
10	T	T	T	T	6	6	T	T	T	T	--	1.2	1.4	1.5	4.5	6	6	6	10	10	13	T	T
16	T	T	T	T	6	6	T	T	T	T	--	--	1	1.2	2	5	5	4.5	10	10	13	T	T
20	T	T	T	T	3.5	3	T	T	T	T	--	--	1	1.2	2	5	5	4.5	10	10	10	T	T
25	T	T	T	T	2.5	2.5	T	T	T	T	--	--	0.4	0.8	1.5	4.5	4.5	4.5	10	10	10	T	T
32	6	6	T	T	--	--	T	T	T	T	--	--	0.5	1.5	2.3	2.3	3	7.5	10	10	10	T	T
40	--	6	T	T	--	--	T	T	T	T	--	--	--	--	--	2.3	2.3	2	7.5	7.5	10	10	T
50	--	3.5	8	10	--	--	--	3.5	T	T	--	--	--	--	--	--	--	2	4.5	6	10	10	T
63	--	--	8	10	--	--	--	--	T	T	--	--	--	--	--	--	--	4.5	6	10	10	10	T
EP250 C curve	6	15	15	T	T	6	6	T	T	T	0.3	1.2	1.8	1.6	4.5	6	6	6	10	10	13	15	15
10	15	15	T	T	6	6	T	T	T	T	--	1.2	1.4	1.5	4.5	6	6	6	10	10	13	15	15
16	15	15	T	T	6	6	T	T	T	T	--	--	1	1.2	2	5	5	4.5	10	10	13	15	15
20	15	15	T	T	3.5	3	T	T	T	T	--	--	1	1.2	2	5	5	4.5	10	10	10	15	15
25	15	15	T	T	2.5	2.5	15	T	T	T	--	--	0.4	0.8	1.5	4.5	4.5	4.5	10	10	10	15	15
32	6	6	10	T	--	--	10	10	T	T	--	--	0.5	1.5	2.3	2.3	3	7.5	10	10	10	15	15
40	--	6	10	T	--	--	10	10	T	T	--	--	--	--	--	2.3	2.3	2	7.5	7.5	10	10	15
50	--	3.5	8	10	--	--	--	3.5	T	T	--	--	--	--	--	--	--	2	4.5	6	10	10	15
63	--	--	8	10	--	--	--	--	T	T	--	--	--	--	--	--	--	4.5	6	10	10	10	15
EP60 B curve	6										0.5	2	3.2	3.5	T	T	T	T	T	T	T	T	T
10											--	1.6	2	2.8	6	T	T	7.5	T	T	T	T	T
16											--	--	1.2	1.4	4	6	6	6	T	T	T	T	T
20											--	--	1.2	1.4	4	6	6	4.5	T	T	T	T	T
25											--	--	--	1.3	3.5	6	6	4.5	T	T	T	T	T
32											--	--	--	1.3	3.5	6	6	3	7.5	T	T	T	T
40											--	--	--	--	1.6	5	5	2	7.5	7.5	T	T	T
50											--	--	--	--	--	--	--	6	7.5	T	T	T	T
63											--	--	--	--	--	--	--	6	7.5	T	T	T	T
EP100 B curve	6										0.5	2	3.2	3.5	10	10	10	T	T	T	T	T	T
10											--	1.6	2	2.8	6	10	10	7.5	T	T	T	T	T
16											--	--	1.2	1.4	4	6	6	6	10	T	T	T	T
20											--	--	1.2	1.4	4	6	6	4.5	10	T	13	T	T
25											--	--	--	1.3	3.5	6	6	4.5	10	10	13	T	T
32											--	--	--	1.3	3.5	6	6	3	7.5	10	10	10	T
40											--	--	--	--	1.6	5	5	2	7.5	7.5	10	10	T
50											--	--	--	--	--	--	--	6	7.5	10	10	10	T
63											--	--	--	--	--	--	--	6	7.5	10	10	10	T
EP250 B curve	6										0.5	2	3.2	3.5	10	10	10	T	T	T	15	T	T
10											--	1.6	2	2.8	6	10	10	7.5	T	T	15	T	T
16											--	--	1.2	1.4	4	6	6	6	10	T	15	T	T
20											--	--	1.2	1.4	4	6	6	4.5	10	T	13	15	T
25											--	--	--	1.3	3.5	6	6	4.5	10	10	13	15	15
32											--	--	--	1.3	3.5	6	6	3	7.5	10	10	10	15
40											--	--	--	--	1.6	5	5	2	7.5	7.5	10	10	15
50											--	--	--	--	--	--	--	6	7.5	10	10	10	15
63											--	--	--	--	--	--	--	6	7.5	10	10	10	15

T = Full selectivity
10 = Selectivity up to 10 kA

Example

A combination of an MCB EP100 C25 with an upstream D160 160A guarantees selectivity up to a short-circuit level of 10 kA.

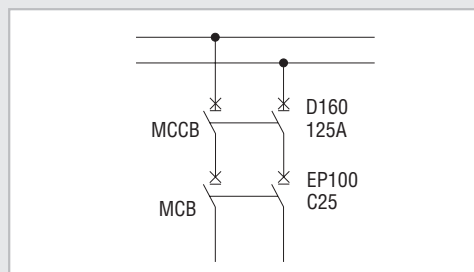

Association (Back-up protection)

Association consists the use of an MCB with lower breaking capacity than the presumed one at the place of its installation. If another protective device installed upstream is co-ordinated so that the energy let-through by these two devices does not exceed that which can be withstood without damage by the device placed downstream and the conductor protected by these devices.

In the event of short-circuit, both protective devices will disconnect, therefore the selectivity between them is considered as partial.

Association reduces the cost of the installation in case of high short-circuit currents.

To obtain association between a breaker and a protective device, several conditions linked to the components characteristic must be fulfilled. Those have been defined by calculation and testing.

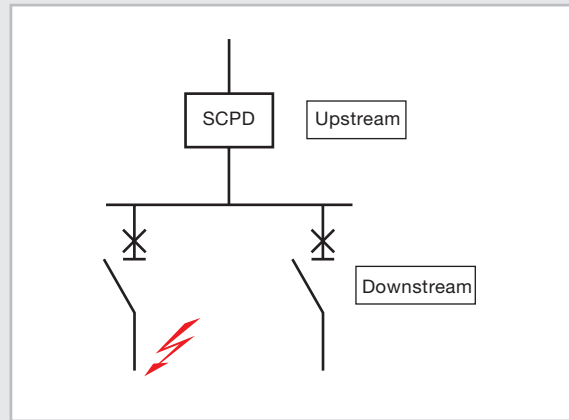

SCPD: Short-Circuit Protective Device

Upstream: Fuses / Downstream: MCB's

Downstream: MCB's ElfaPlus		Upstream: fuses			
Series	In (A)	Type gG		Type aM	
		min. rating (A)	max. rating (A)	min. rating (A)	max. rating (A)
EP 60	1	4	–	2	–
EP 100	2	8	63	4	63
EP 250	3	10	63	6	63
	6	20 (10*)	80	10 (10*)	63
	10	25 (16*)	80	16 (6*)	80
	16	40 (20*)	80	20 (10*)	80
	20	50 (32*)	100	25 (16*)	80
	25	63 (40*)	100	32 (20*)	80
	32	80 (50*)	100	40 (25*)	100
	40	100 (50*)	125	50 (32*)	125
	50	125 (63*)	160	63 (40*)	160
	63	160 (80*)	160	80 (50*)	160
Hti	80	160	200	125	125
	100	200	200	125	125
	125	250	250	125	125

Icc max: 100 kA (80 kA, 400V with 10x38 cartridge fuses) * In case of MCB with B characteristics

Upstream: MCB's ElfaPlus / Downstream: MCB's ElfaPlus

Voltage 400/415V, Icc max. in kA			Upstream: MCB's ElfaPlus		
Downstream: MCB's ElfaPlus			Upstream: MCB's ElfaPlus		
Series	In (A)		EP100 0.5 ... 63A	EP250 ≤ 40A	EP250 50 ... 63A
EP60	0.5 ... 63		10	20	15
EP100	0.5 ... 63		-	20	15

Voltage 220/240V, Icc max. in kA			Upstream: MCB's ElfaPlus			
Downstream: MCB's ElfaPlus			Upstream: MCB's ElfaPlus			
Series	In (A)		EP60 0.5 ... 63A	EP100 0.5 ... 63A	EP250 0.5 ... 63A	Hti 80 ... 125A
CP60	6, 10		6	15	20	-
CP60	16, 20		6	20	20	-
CP60	25, 32		6	20	22	-
EP60	0.5 ... 63		-	20	22	16
EP100	≤ 32		-	-	50	-
EP100	≥ 40		-	-	35	-

Upstream: MCCB's Record / Downstream: MCB's ElfaPlus

Voltage 400/415V, Icc max. in kA			Upstream: Record breakers (MCCB's)											
Downstream: MCB's ElfaPlus			Upstream: Record breakers (MCCB's)											
Series	In (A)	Icu (kA)	FD125S 30kA	D125 25kA	D125L 100kA	D160 30kA	DH160 50kA	D160L 100kA	D250 35kA	DH250 50kA	D250L 100kA	D400 35kA	DH400 50kA	D400L 100kA
EP60	≤ 32	10	22	22	100	30	40	50	35	40	50	22	22	25
EP60	≥ 40	10	15	22	100	30	40	50	35	40	50	22	22	25
EP100	≤ 32	15	25	22	100	30	40	50	35	40	50	22	22	25
EP100	≥ 40	15	22	22	100	30	40	50	35	40	50	22	22	25
EP250	≤ 32	25	30	-	100	30	40	50	35	40	50	-	-	25
EP250	≥ 40	15	25	-	100	30	40	50	35	40	50	22	22	25
Hti	80 ... 125	10	25	25	50	15	15	50	15	15	50	50	-	-

Voltage 220/240V, Icc max. in kA			Upstream: Record breakers (MCCB's)										
Downstream: MCB's ElfaPlus			Upstream: Record breakers (MCCB's)										
Series	In (A)	Icu (kA)	D125 100kA	D125L 130kA	D160 70kA	DH160 80kA	D160L 130kA	D250 70kA	DH250 80kA	D250L 130kA	D400 50kA	DH400 70kA	D400L 130kA
EP60	0.5 ... 63	20	20	-	-	-	-	-	-	-	-	-	-
EP100	0.5 ... 63	30	50	130	50	50	50	50	50	50	22	22	25
EP250	≤ 32	50	80	130	70	80	100	70	80	100	50	50	70
EP250	≥ 40	30	80	130	65	65	100	65	65	100	50	50	70
Hti	80 ... 125	15	30	130	30	30	100	30	30	100	50	30	30

Use in DC

Selection criteria

The selection of an MCB to protect a D.C. installation depends on the following parameters:

- The nominal current
- The nominal voltage of the power supply, which determines the number of poles to switch the device
- The maximum short-circuit current, to determine the short-circuit capacity of the MCB
- Type of power supply

In the event of an insulation fault, it is considered as an overload when one pole or an intermediate connection of the power supply is connected to earth, and the conductive parts of the installation are also connected to earth.

Insulated generator

In insulated generators there is no earth connection, therefore an earth leakage in any pole has no consequence. In the event of fault between the two poles (+ and -) there is a short-circuit in the installation which value will depend on the impedance of the installation as well as of the voltage U_n . Each polarity shall be provided with the appropriate number of poles.

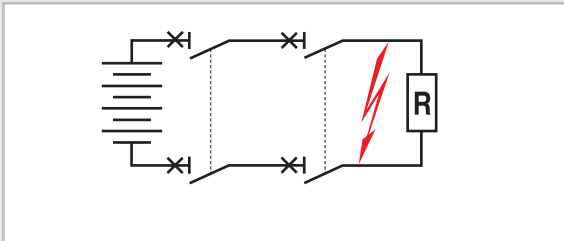

Generator with one earthed pole

In the event of a fault occurring in the earthed pole (-) there is no consequence. In the event of a fault between the two poles (+ and -) or between the pole + and earth, then there is a short-circuit in the installation which value depends on the impedance of the installation as well as of the voltage U_n . The unearthed pole (+) shall be provided with the necessary numbers of poles to break the maximum short-circuit.

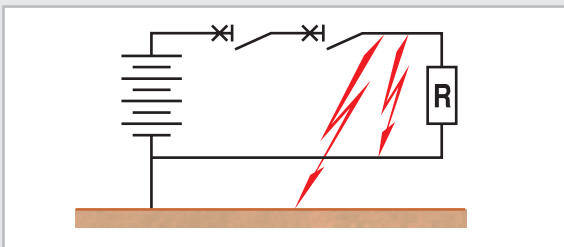

Generator with centre point earth connection

In the event of short-circuit between any pole (+ or -) and earth, there is a $I_{sc} < I_{sc\ max}$ because the voltage is $U_n/2$. If the fault occurs between the two poles there is a short-circuit in the installation which value depends on the impedance of the installation as well as the voltage U_n .

Each polarity shall be provided with the necessary number of poles to break the maximum short-circuit at $U_n/2$.

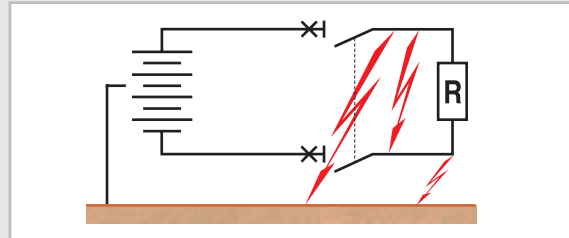

Use of standard MCB in DC

For MCB's designed to be used in alternating current but used in installations in direct current, the following should be taken into consideration:

- For protection against overloads it is necessary to connect the two poles to the MCB. In these conditions the tripping characteristic of the MCB in direct current is similar in alternating current.

- For protection against short-circuits it is necessary to connect the two poles to the MCB. In these conditions the tripping characteristic of the MCB in direct current is 40% higher than the one in alternating current.

Use of special MCB (UC) in DC (UC= Universal Current)

For MCB's designed to work in both alternating and direct current, it is necessary to respect the polarity of the terminals since the device is equipped with a permanent magnet.

Use in DC selection table

Series	Rated current (A)	60 V 1 pole Icu (kA)	125 V 2 poles in series Icu (kA)	250 V 1 pole Icu (kA)	440 V 2 poles in series Icu (kA)
EP60	0.5...63A	20	25	-	-
EP100	0.5...63A	25	30	-	-
EP100UC	0.5...63A	-	-	6	6
EP250	6...25A	10	10	-	-

Installation of MCB's series EP100 UC in direct current

Example of utilisation for maximum voltage between lines according to the number of poles

MCB's	EP 100 UC 1P	EP 100 UC 2P		EP 100 UC 4P
Maximum voltage between lines	250 V	250 V	440 V	440 V
Maximum voltage between lines and earth	250 V	250 V	440 V (1)	250 V
Power supply at bottom terminals				
Power supply at top terminals				

(1) Negative pole connected to earth

Example of utilisation for different voltages between line and earth than between two lines

MCB's	EP 100 UC 2P		EP 100 UC 4P
Maximum voltage between lines	440 VDC Multipole breaking	440 VDC Multipole breaking	440 VDC Multipole breaking
Maximum voltage between lines and earth	250 VDC Generator with centre point earth connection	440 VDC Generator without earth connection or with one earthed pole	440 VDC Generator without earth connection or with one earthed pole

Influence of ambient air temperature on the rated current

The maximum value of the current which can flow through a MCB depends of the nominal current of the MCB, the conductor cross-section as well as of the ambient air temperature.

The values shown in the table below are for devices in the free air. For devices installed with other modular devices in the same switchboard a correction factor (K) shall be applied relative to the mounting situation of the MCB, the ambient temperature and the number of main circuits in the installation (EN 60439-1):

Nr of devices	K
2 or 3	0.9
4 or 5	0.8
6 to 9	0.7
> 10	0.6

Calculation example

Within a distribution panel consisting of eight MCB 2PC16 with an operating ambient temperature of 45°C, which is the highest temperature the MCB can operate without unwanted tripping.

Calculation

The correction factor $K=0.7$, for use in a eight circuit installation: $16A \times 0.7 = 11.2A$

As the MCB is working at 45°C it shall be applied another factor (90% = 0.9):

$In \text{ at } 45^\circ\text{C} = In \text{ at } 30^\circ\text{C} \times 0.9 = 11.2A \times 0.9 = 10.1A$

The thermal callibration of the MCB's was carried out at ambient temperature of 30°C. Ambient temperatures different from 30°C influence the bimetal and this results in earlier or later thermal tripping.

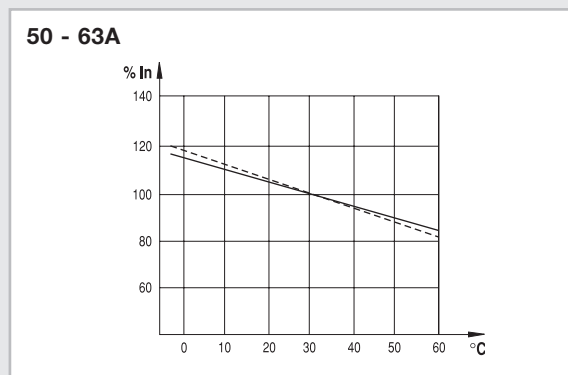
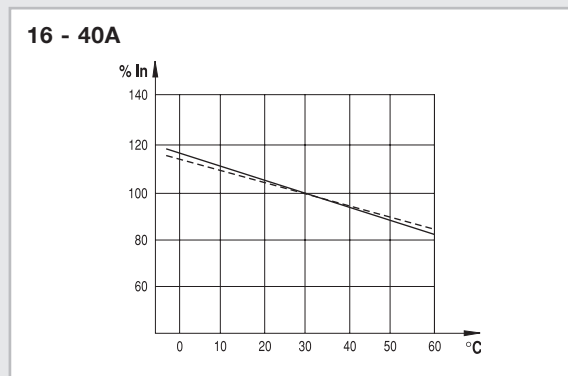
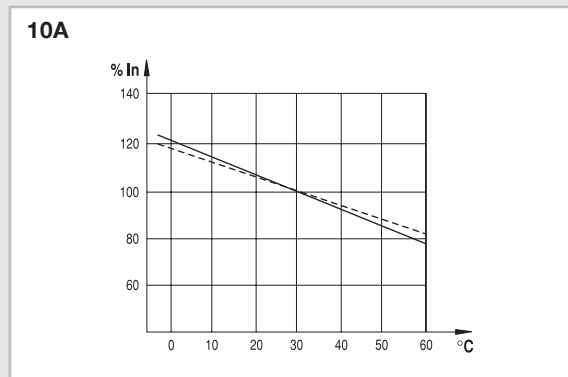
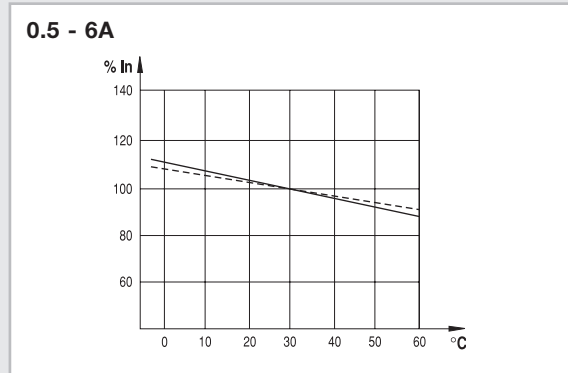

———— : 1P (Single pole)
 - - - - - : mP (Multipole)



Effects of frequency on the tripping characteristic

All the MCB's are designed to work at frequencies of 50-60 Hz, therefore to work at different values, consideration must be given to the variation of the tripping characteristics. The thermal tripping does not change with variation of the frequency but the magnetic tripping values can be up to 50% higher than the ones at 50-60 Hz.

Tripping current variation

60Hz	100Hz	200Hz	300Hz	400Hz
1	1.1	1.2	1.4	1.5

Power losses

The power losses are calculated by measuring the voltage drop between the incoming and the outgoing terminals of the device at rated current.

Power loss per pole

In (A)	Voltage drop (V)	Energy loss (W)	Resistance (mOhm)
0.5	2.230	1.115	4458.00
1	1.270	1.272	1272.00
2	0.620	1.240	310.00
3	0.520	1.557	173.00
4	0.370	1.488	93.00
6	0.260	1.570	43.60
8	0.160	1.242	19.40
10	0.160	1.560	15.60
13	0.155	2.011	11.90
16	0.162	2.586	10.10
20	0.138	2.760	6.90
25	0.128	3.188	5.10
32	0.096	3.072	3.00
40	0.100	4.000	2.50
50	0.090	4.500	1.80
63	0.082	5.160	1.30
80	0.075	6.000	0.90
100	0.075	7.500	0.75
125	0.076	9.500	0.60

Limitation curves

Let-through energy I^2t

The limitation capacity of a MCB in short-circuit conditions, is its capacity to reduce the value of the let-through energy that the short-circuit would be generating.

Peak current I_p

It is the value of the maximum peak of the short-circuit current limited by the MCB.

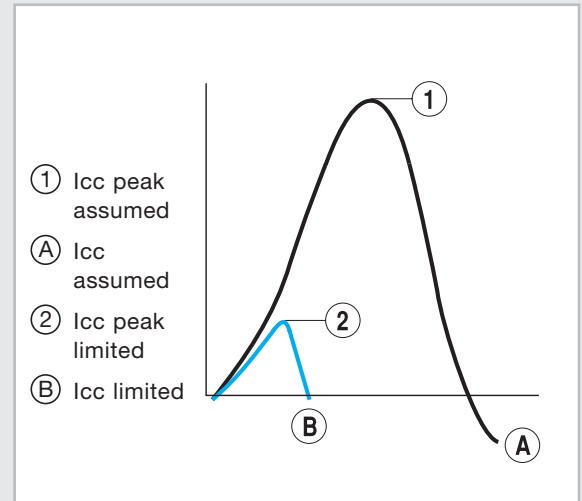

See page T1.25 up to T1.31

EP60 Curve B

I²t Let-through energy at 240/415 V

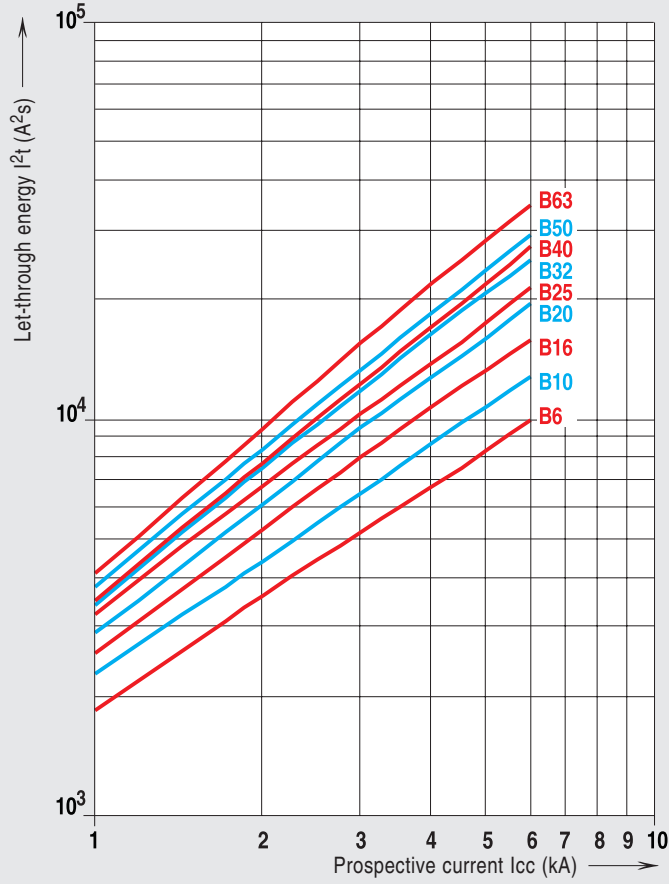

I_d Limited peak current at 230/400 V

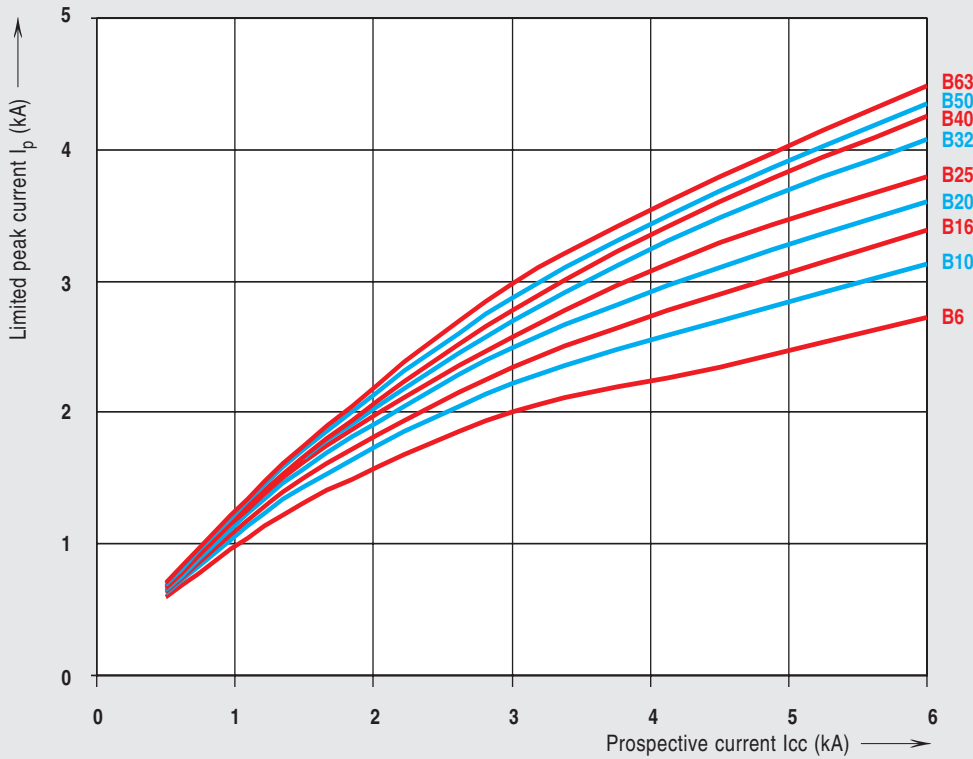

EP60 Curve C

I²t Let-through energy at 240/415 V

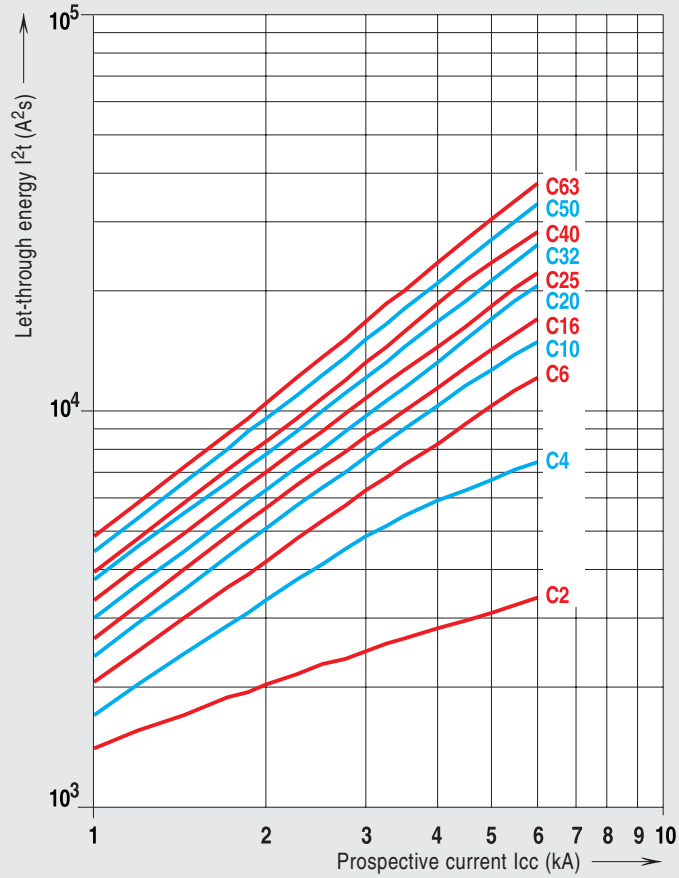

I_d Limited peak current at 230/400 V

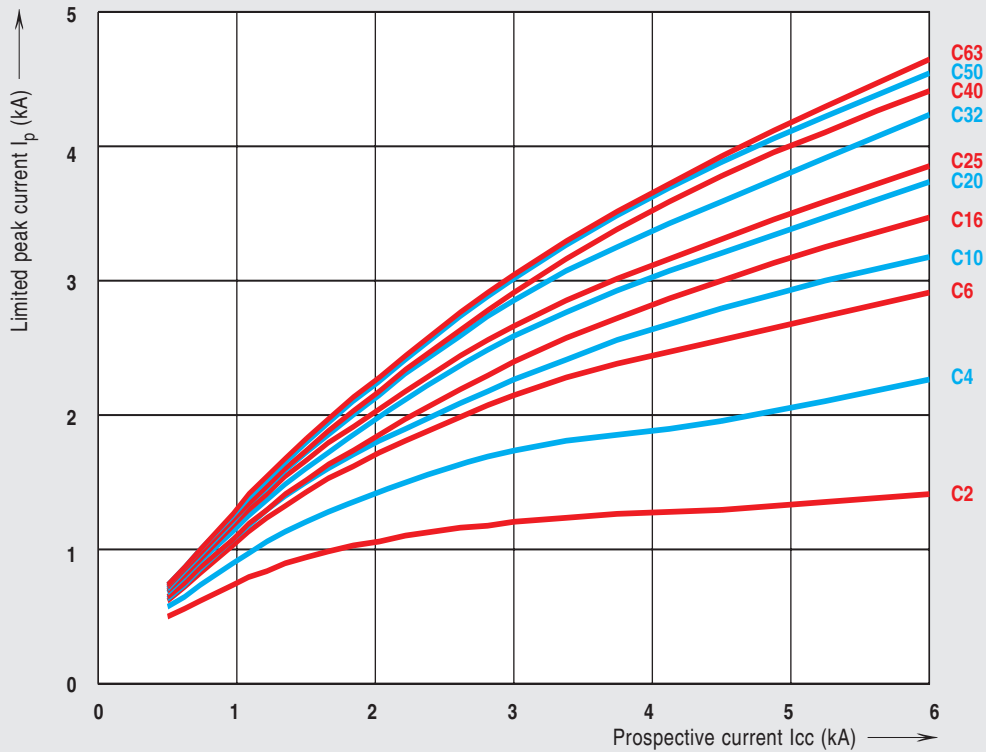

EP60 Curve D

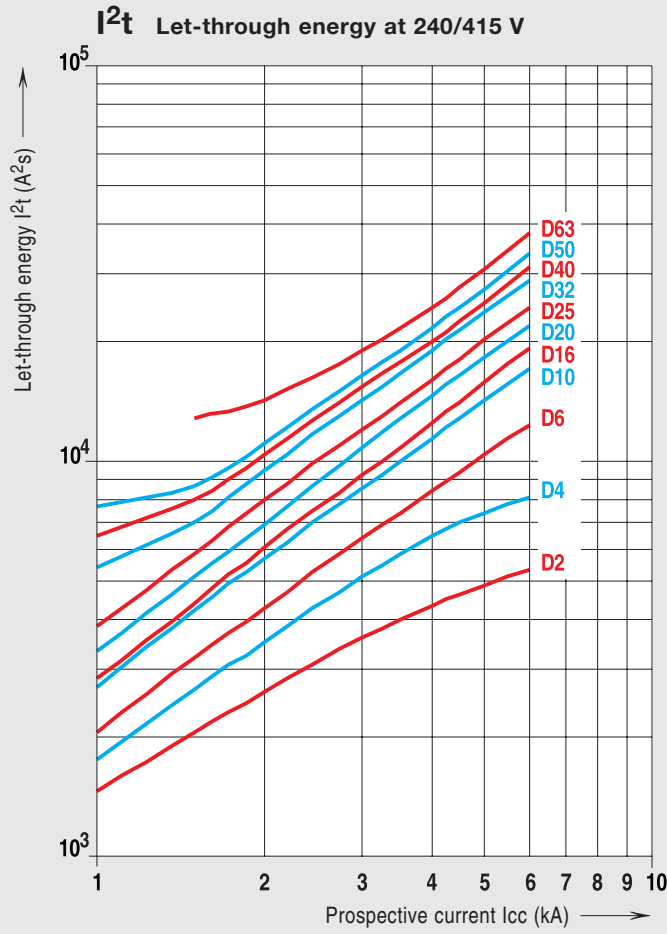

I_d Limited peak current at 230/400 V

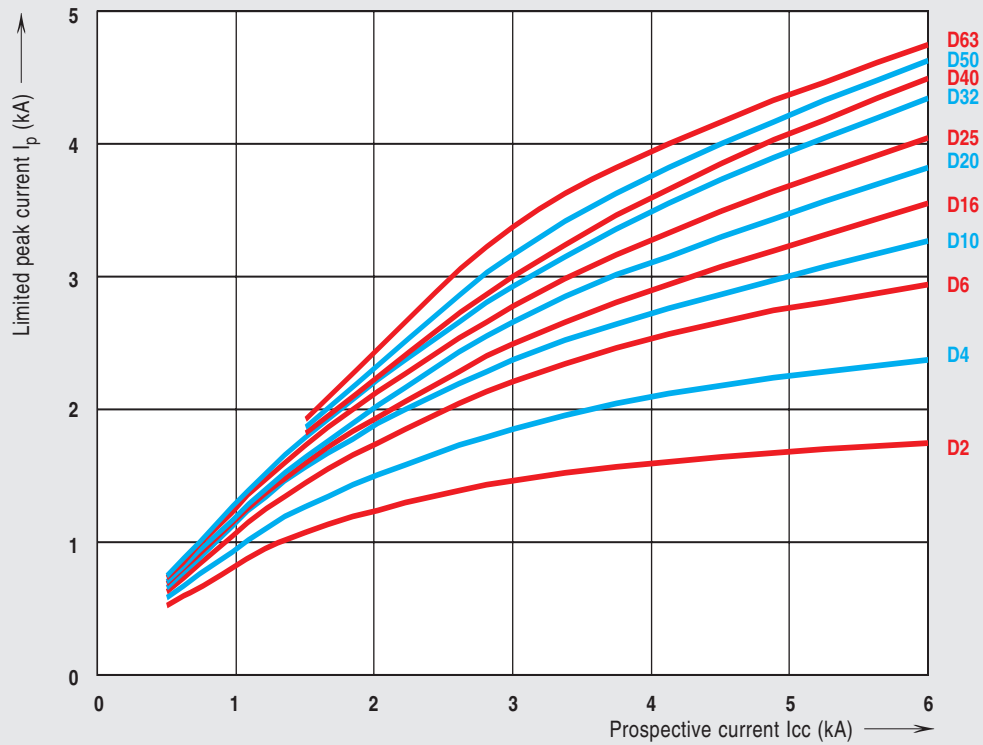

EP100 Curve B

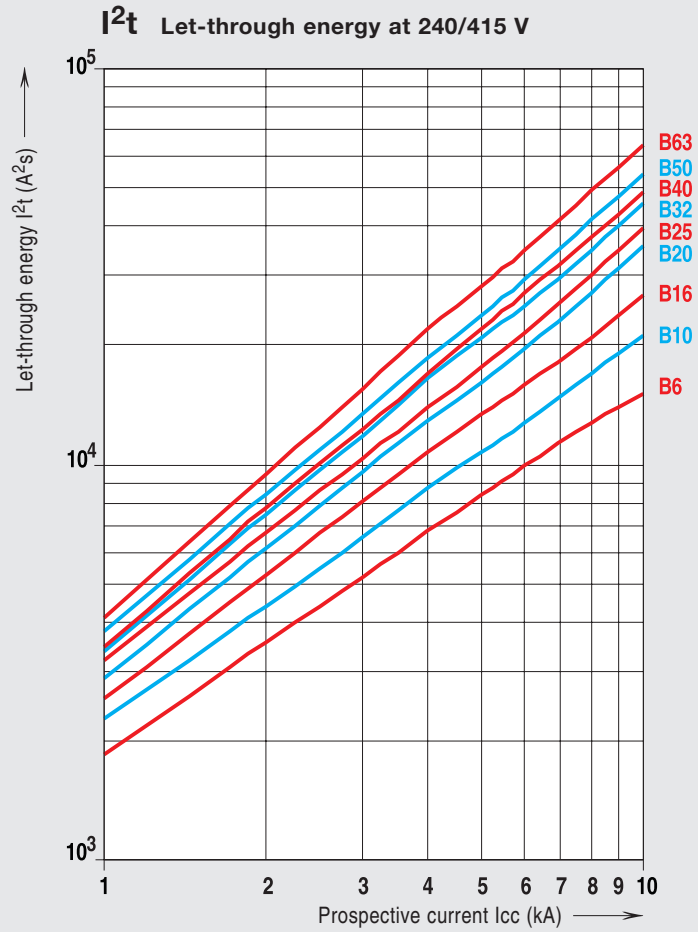

I_d Limited peak current at 230/400 V

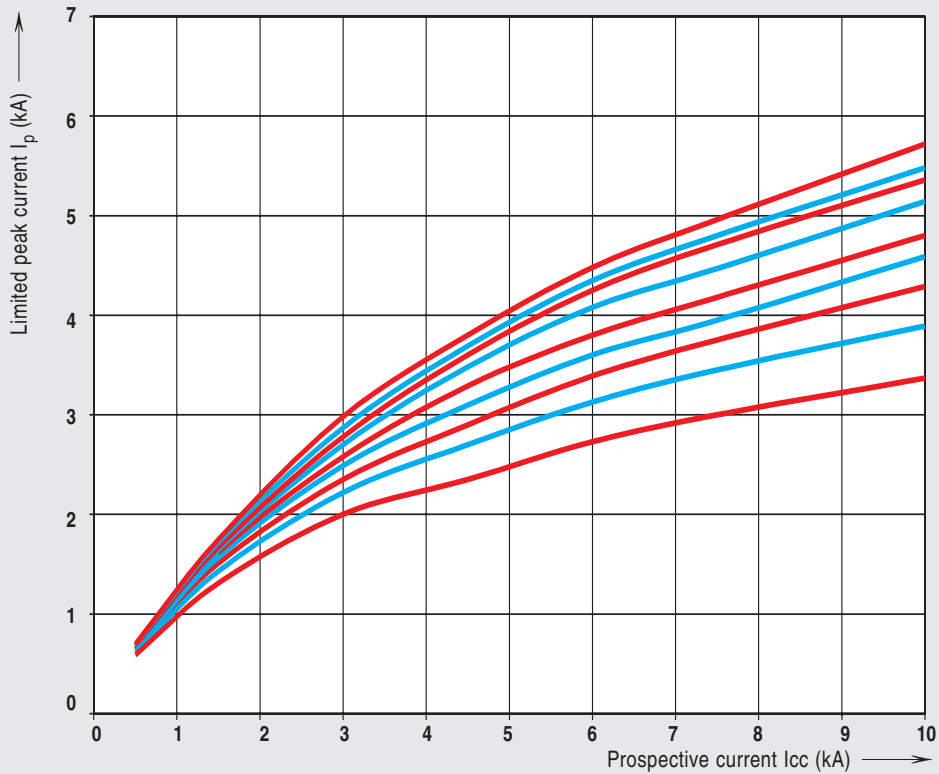

EP100 Curve C

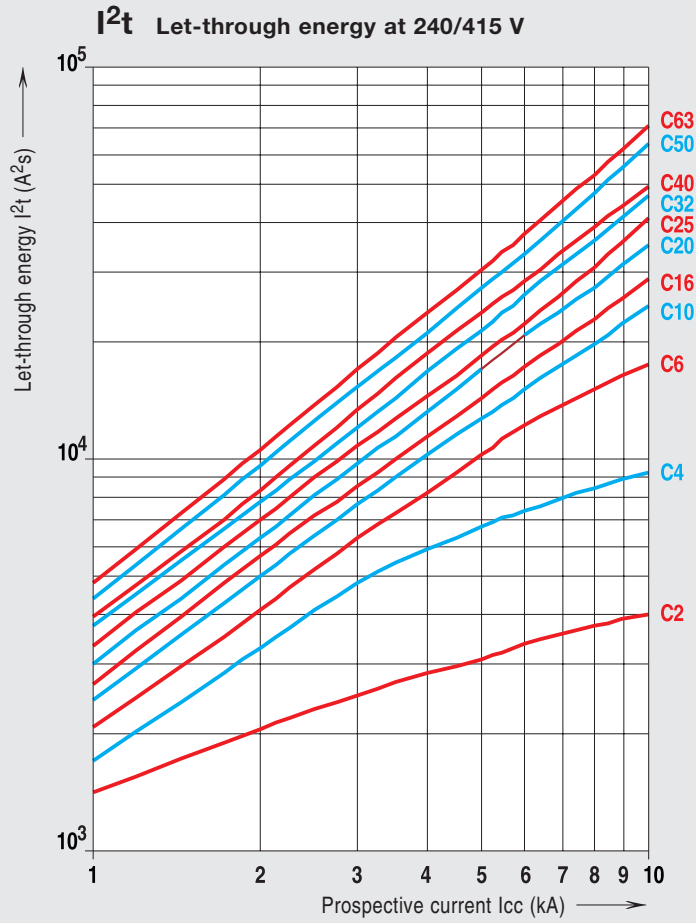

I_d Limited peak current at 230/400 V

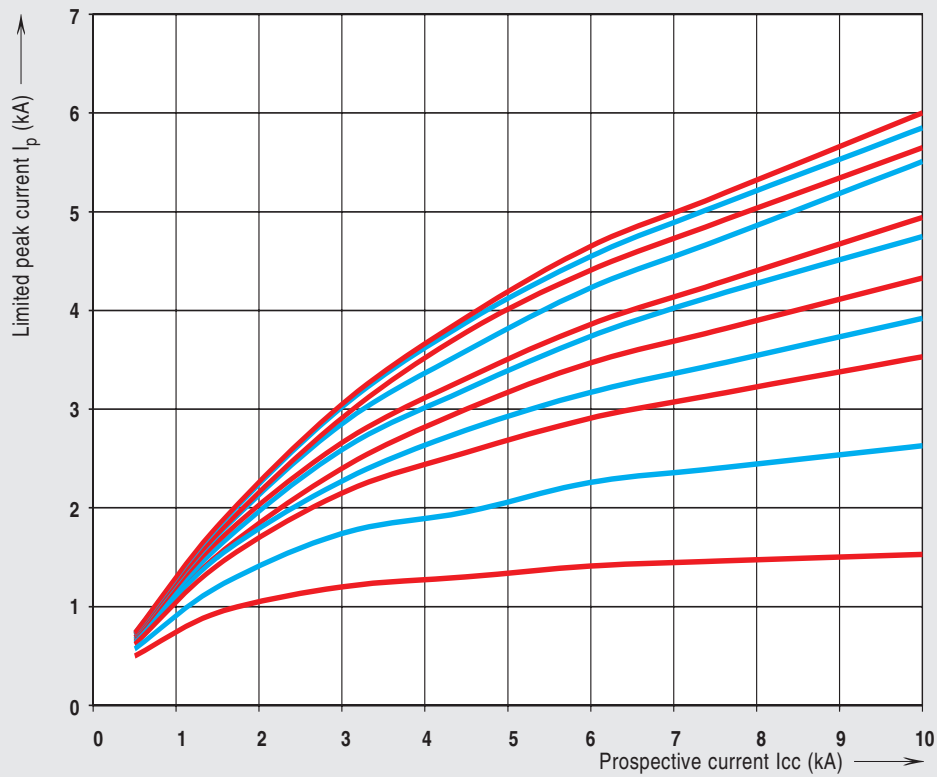

EP100 Curve D

I²t Let-through energy at 240/415 V

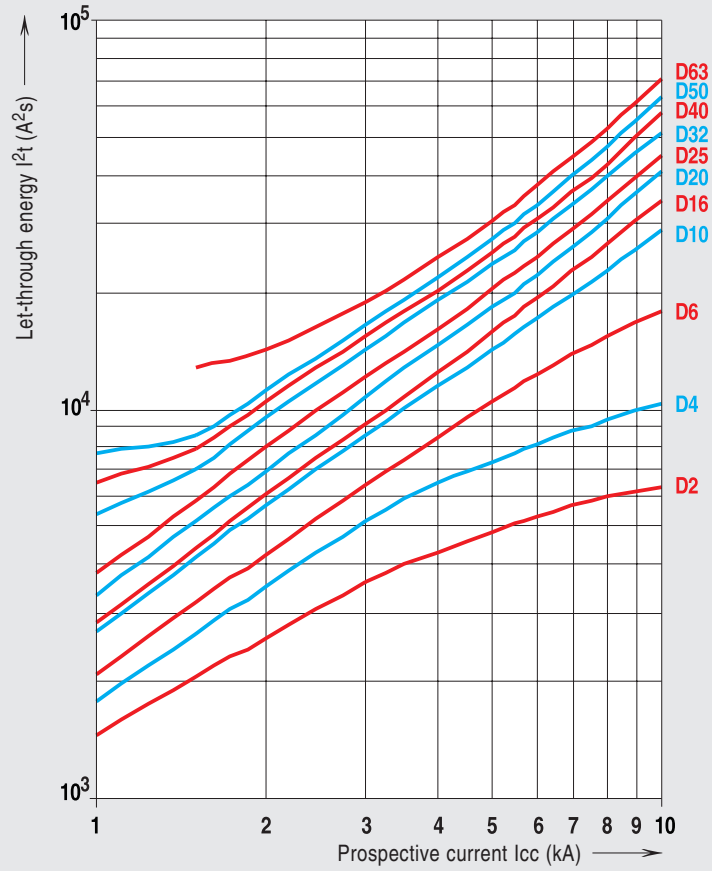

I_d Limited peak current at 230/400 V

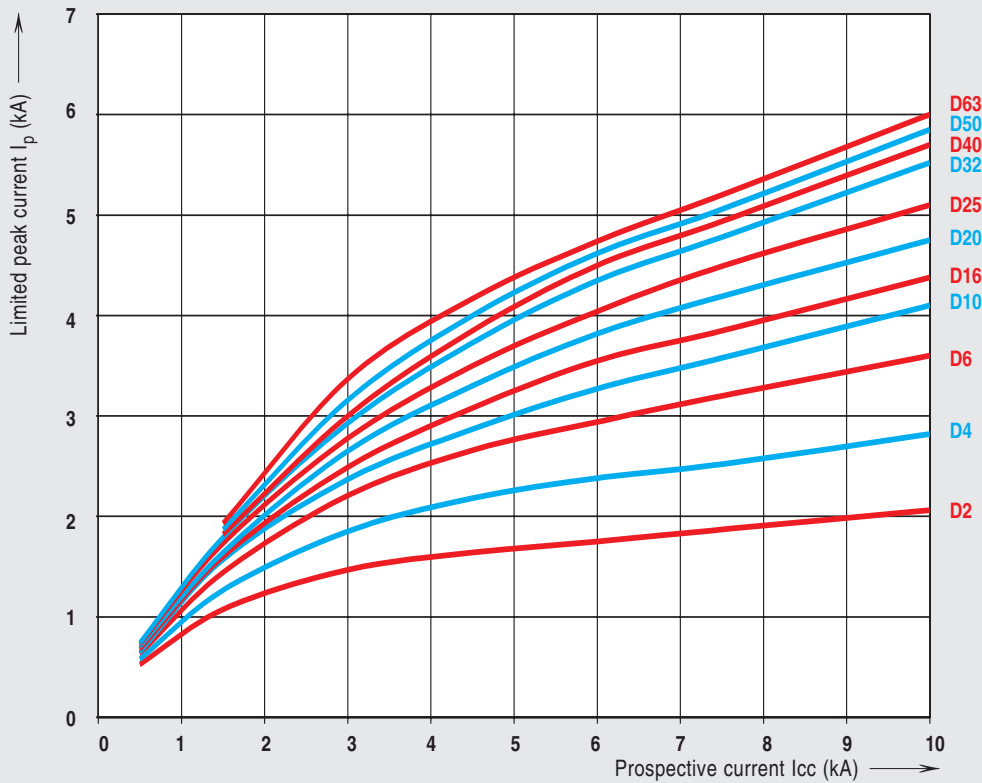

EP250 Curve B

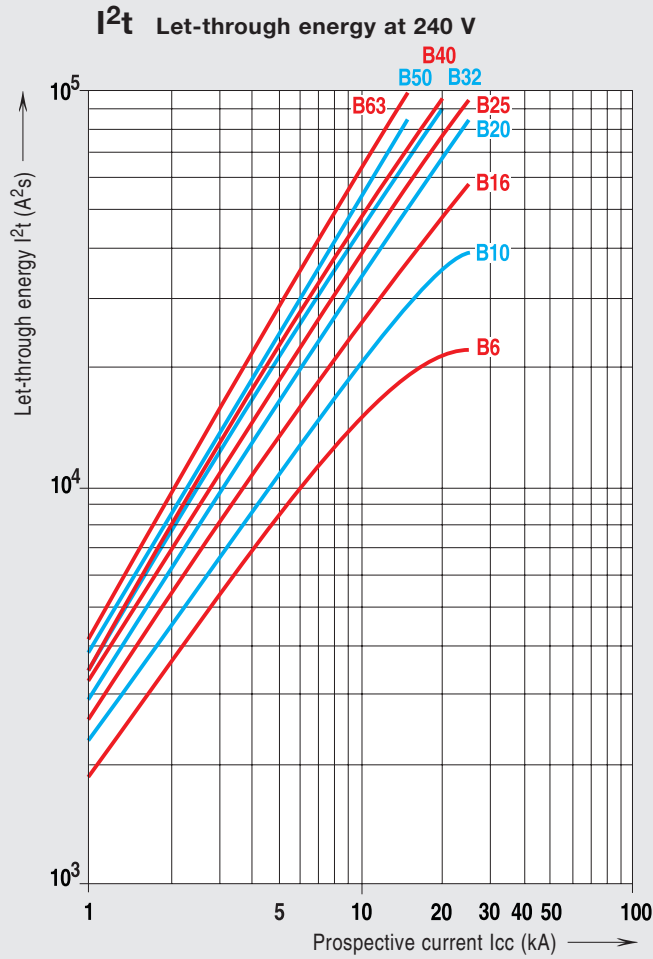

EP250 Curve C

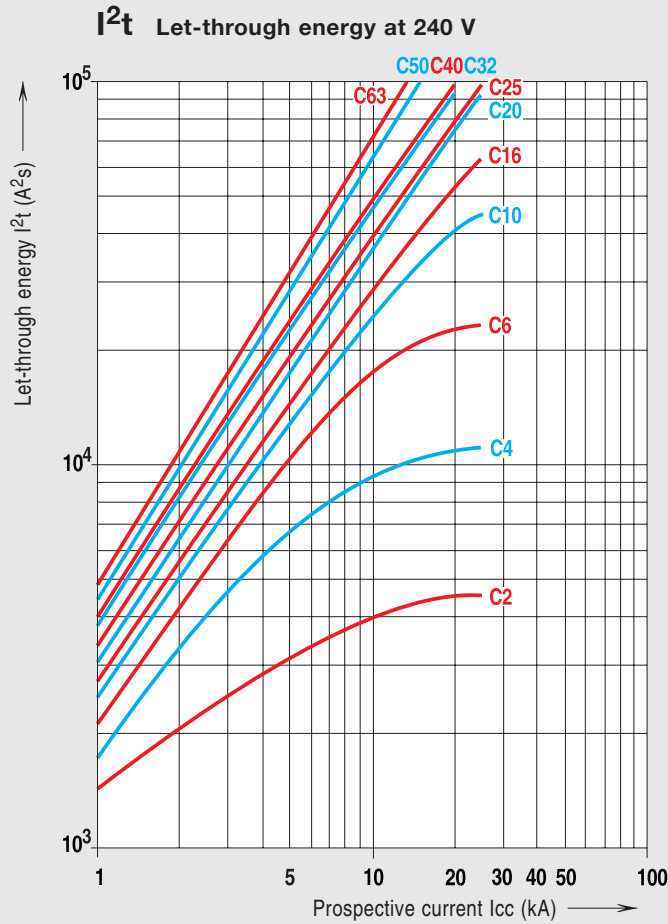

Tripping curves acc. EN 60898

The following tables show the average tripping curves of the GE Power Controls MCB's based on the thermal and magnetic characteristic.

Curve B

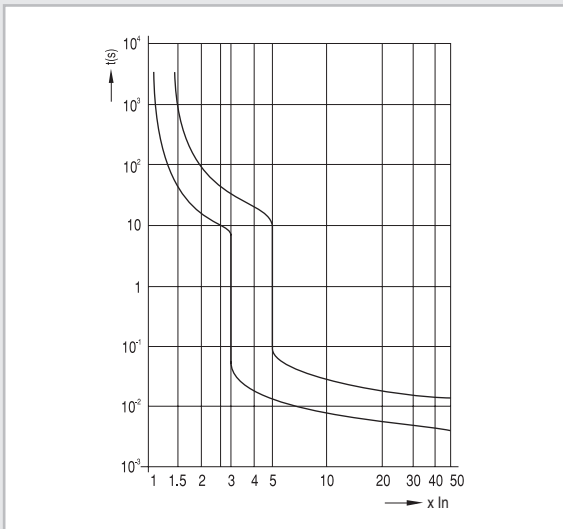

Curve D

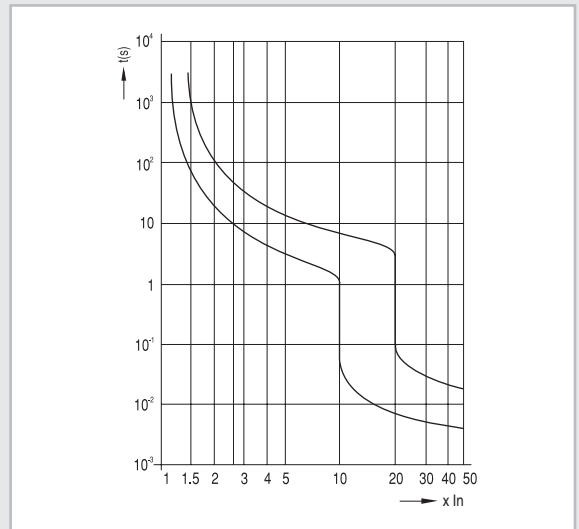

Curve C

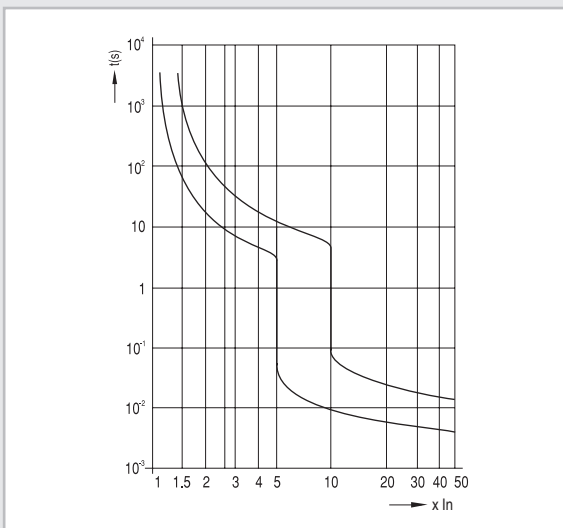

Text for specifiers

MCB Series EP 60/100

- According to EN 60898 standard
- For DIN rail mounting according to DIN EN 50022; EN 50022; future EN 60715; IEC 60715 (top hat rail 35 mm)
- Grid distance 35 mm
- Working ambient temperature from -25°C up to +50°C
- Approved by CEBEC, VDE, KEMA, IMQ...
- 1 pole is a module of 18 mm wide
- Nominal rated currents are: 0.5/1/2/3/4/6/10/13/16/20/25/32/40/50/63 A
- Tripping characteristics: B,C,D
- Number of poles: 1P, 1P+N, 2P, 3P, 3P+N, 4P
- The short-circuit breaking capacity is: 3/4.5/6/10kA, energy limiting class 3
- Terminal capacity from 1 up to 35mm² rigid wire or 1.5 up to 25 mm² flexible wire.
- Screw head suitable for flat or Pozidriv screwdriver
- Can be connected by means of both pin or fork busbars
- The toggle can be sealed in ON or OFF position
- Rapid closing
- Both incoming and outgoing terminals have a protection degree of IP20 and they are sealable
- Isolator function thanks to the printing Red/Green on the toggle.
- Maximum voltage between two phases; 440V~
- Maximum voltage for utilisation in DC current: 48 V 1P and 110 V 2P
- Two position rail clip
- Mechanical shock resistance 40g (direction x, y, z) minimum 18 shocks 5 ms halvesinusoidal acc. to IEC 60068-2-27
- Vibrations resistance: 3g (direction x, y, z) minimum 30 min. according to IEC 60068-2-6
- Extensions can be added on both left or right hand side
 - Auxiliary contact
 - Shunt trip
 - Undervoltage release
 - Motor operator
 - Panel board switch
- MCB's have a circuit indicator for easy circuit identification
- Add-on RCD can be coupled

MCB Series EP250

- According to EN 60947.2 standard
- For DIN rail mounting according to DIN EN 50022; EN 50022; future EN 60715; IEC 60715 (top hat rail 35 mm)
- Working ambient temperature from -25°C up to +50°C
- 1 pole is a module of 18 mm wide
- Nominal rated currents are: 0.5/1/2/3/4/6/10/13/16/20/25/32/40/50/63 A
- Tripping characteristics: B,C
- Number of poles: 1P, 2P, 3P, 4P
- The short-circuit capacity is: 10/15/25 kA
- Terminal capacity from 1 up to 35mm² rigid wire or 1.5 up to 25 mm² flexible wire
- Screw head suitable for flat or Pozidriv screwdriver
- Can be connected by means of both pin or fork busbars
- The toggle can be sealed in ON or OFF position
- Rapid closing
- Both incoming and outgoing terminals have a protection degree of IP20 and they are sealable
- Isolator function thanks to the printing Red/Green on the toggle.
- Maximum voltage between two phases; 440V~
- Maximum voltage for utilisation in DC current: 48 V 1P and 110 V 2P
- Two position rail clip
- Mechanical shock resistance 40g (direction x, y, z) minimum 18 shocks 5 ms halvesinusoidal acc. to IEC 60068-2-27
- Vibrations resistance: 3g (direction x, y, z) minimum 30 min. according to IEC 60068-2-6
- Extensions can be added on both left or right hand side
 - Auxiliary contact
 - Shunt trip
 - Undervoltage release
 - Motor operator
 - Panel board switch
- MCB's have a circuit indicator for easy circuit identification
- Add-on RCD can be coupled



MCB Series EP100 UC

- According to EN 60898-2 standard
- For DIN rail mounting according to DIN EN 50022; EN 50022; future EN 60715; IEC 60715 (top hat rail 35 mm)
- Grid distance 35 mm
- Working ambient temperature from -25°C up to +50°C
- 1 pole is a module of 18 mm wide
- Nominal rated currents are: 0.5/1/2/3/4/6/10/13/16/20/25/32/40/50/63 A
- Tripping characteristics: B, C
- Number of poles: 1P, 2P
- The short-circuit breaking capacity is: 6 kA, "energy limiting" class 3
- Terminal capacity from 1 up to 35mm² rigid wire or 1.5 up to 25 mm² flexible wire
- Screw head suitable for flat or Pozidriv screwdriver
- Can be connected by means of both pin or fork busbars
- The toggle can be sealed in ON or OFF position
- Rapid closing
- Both incoming and outgoing terminals have a protection degree of IP20 and they are sealable
- Isolator function thanks to the printing Red/Green on the toggle.
- Maximum voltage: 1P - 250 V \equiv
2P - 440 V \equiv . Poles in series
- Two position rail clip
- Mechanical shock resistance 40g (direction x, y, z) minimum 18 shocks 5 ms halfsinusoidal according to IEC 60068-2-27
- Vibrations resistance: 3g (direction x, y, z) minimum 30 min. according to IEC 60068-2-6
- Extensions can be added on both left or right hand side
 - Auxiliary contact
 - Shunt trip
 - Undervoltage release
 - Motor operator
 - Panel board switch
- MCB's have a circuit indicator for easy circuit identification
- Add-on RCD can be coupled

MCB Series Hti

- According to EN 60947.2 standard
- For DIN rail mounting according to DIN EN 50022; EN 50022; future EN 60715; IEC 60715 (top hat rail 35 mm)
- Working ambient temperature from -25°C up to +50°C
- 1 pole is a module 1.5 module (27mm)
- Nominal rated currents are: 80/100/125A
- Tripping characteristics: B, C, D
- Number of poles: 1P, 2P, 3P, 4P
- The short-circuit capacity is: 10kA
- Terminal capacity from 2.5 up to 70mm²
- The toggle can be sealed in ON or OFF position
- Both incoming and outgoing terminals have a protection degree of IP20 and they are sealable
- Isolator function thanks to the printing red/green on the toggle. It can be used as main switch
- Maximum voltage between two phases: 440V~
- Two position rail clip
- Mechanical shock resistance 40g (direction x, y, z) minimum 18 shocks 5 ms halfsinusoidal according to IEC 60068-2-27
- Extensions can be added
 - Auxiliary contact
 - Shunt trip
 - Undervoltage release
- Endurance:
 - Mechanical: 10000 operations
 - Electrical: 4000 operations
- Add-on RCD can be coupled

